

Fundamentals of Power Electronics

Dr. Walid Issa | ECT Programme Leader

[Watch Webinar Recording Here](#)



What is Power Electronics ?

The term power electronics refers to solid-state electronic devices used for the conversion and control of electric power.

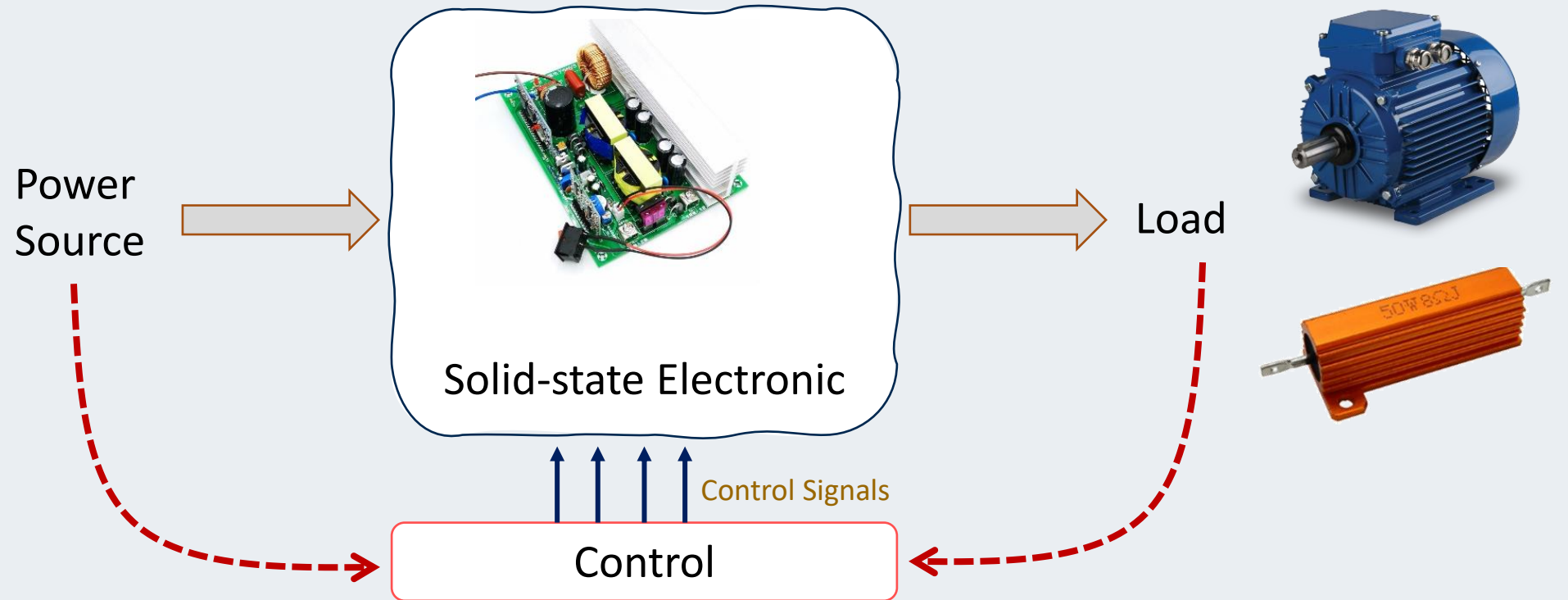
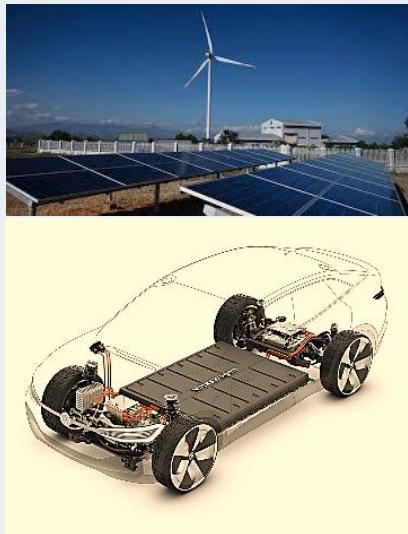

Power Electronics is a field which combines Electric Power, Electronics and Control

What does Power Electronics do ?

Efficient, flexible control and conversion of electrical energy

AC sources: single phase or three phase AC

AC loads: machines, power transmission and distribution systems

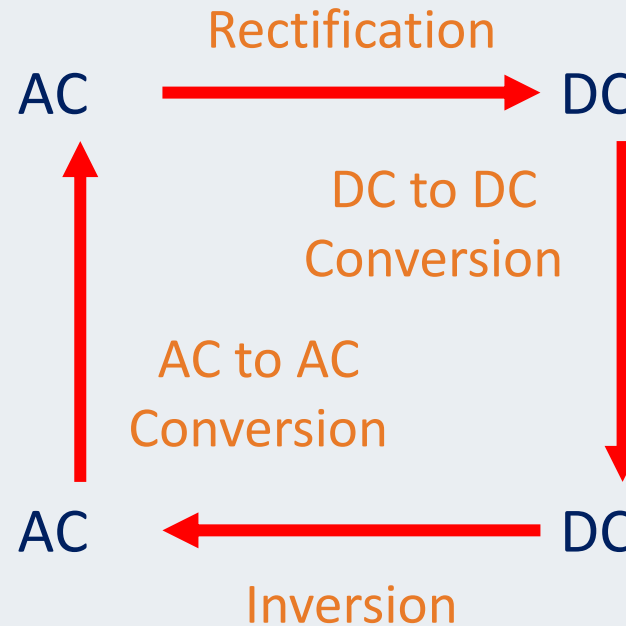

DC loads : heater, lamp, DC motor
DC sources : batteries, solar panel, power supply

DC loads :
electronic circuits, machines

Power Electronic Applications

- **Commercial/Industrial Applications**

Heating Systems Ventilating, Air Conditioners, Central Refrigeration, Lighting, Computers and Office equipment, Uninterruptible Power Supplies (UPS), Elevators, and Emergency Lamps.



- **Domestic Applications**

Cooking Equipment, Lighting, Heating, Air Conditioners, Refrigerators & Freezers, Personal Computers, Entertainment Equipment, UPS

Power Electronic Applications

- **Aerospace Applications**
Space shuttle power supply systems, satellite power systems, aircraft power systems.
- **Telecommunications**
Battery chargers, power supplies (DC and UPS), mobile cell phone battery chargers.
- **Transportation**
Traction control of electric vehicles, battery chargers for electric vehicles, electric locomotives, street cars, trolley buses, automobile electronics including engine controls.

The Market

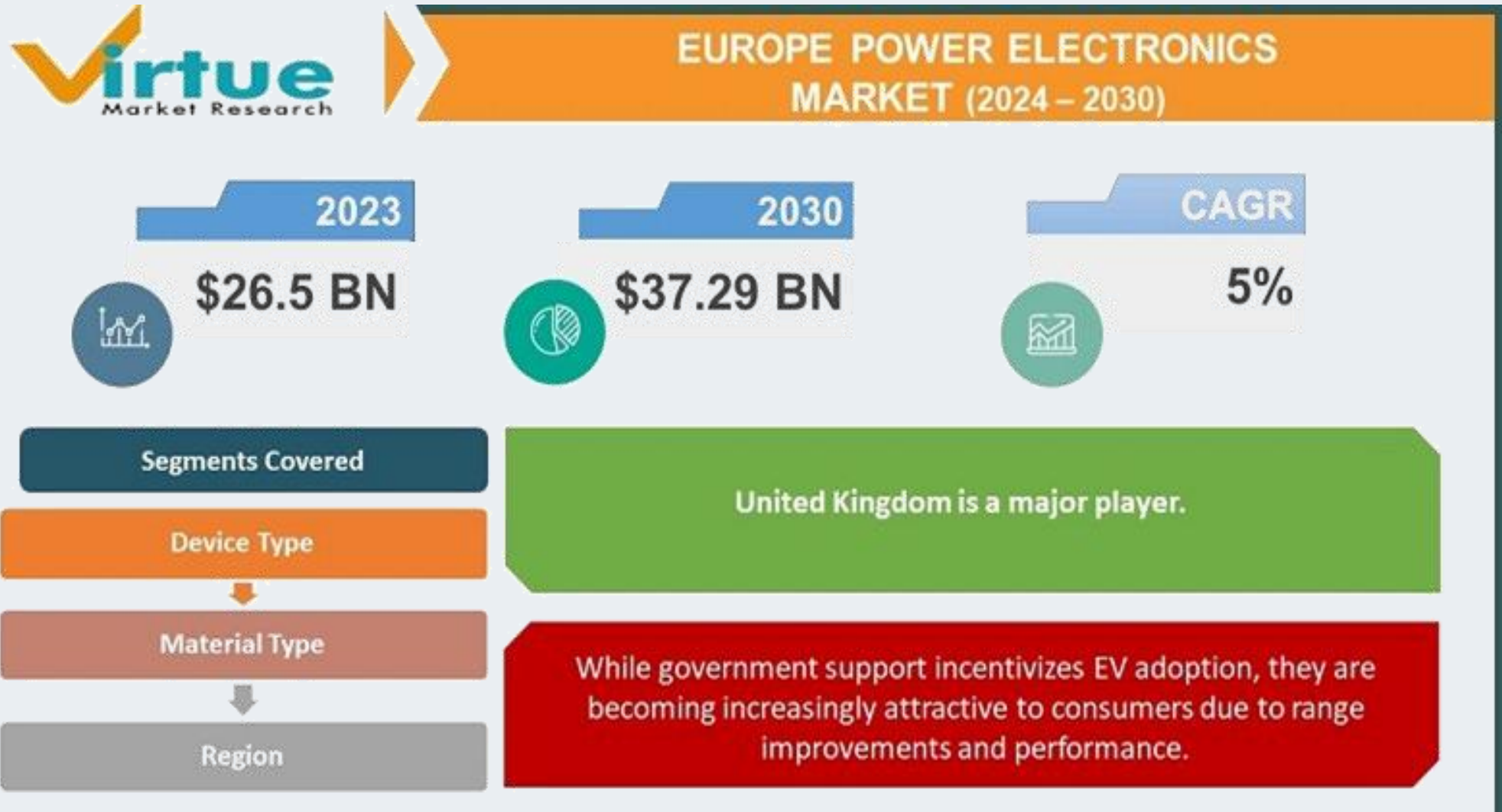

The Market

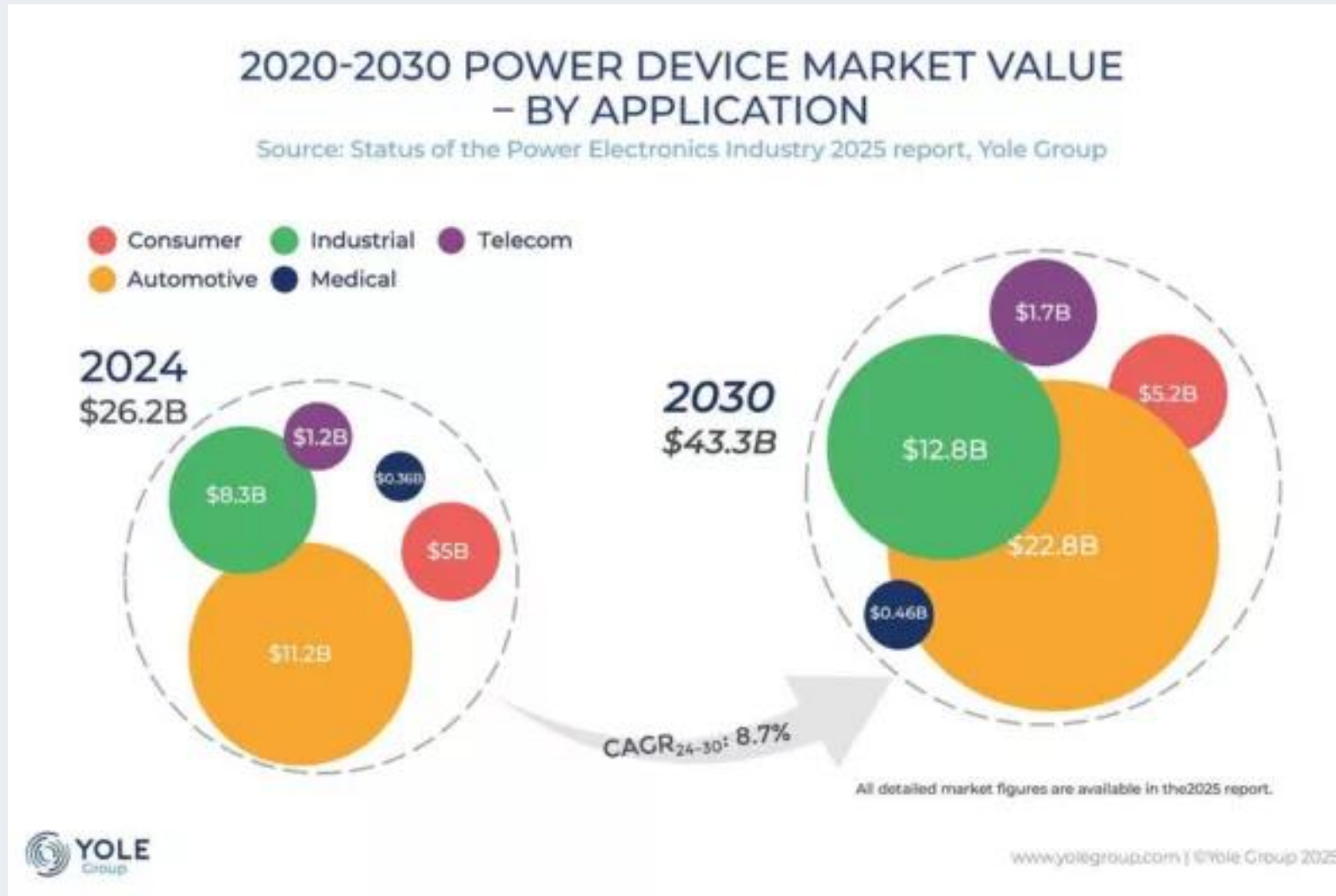

The Market

| | |
|-----------------------|---|
| Job title: | Power Electronics Engineer (Systems Level Inverters & Drives) |
| Job type: | Permanent |
| Emp type: | Full-time |
| Functional Expertise: | Hardware Engineering |
| Skills: | Power Electronics Inverters DC-DC AC-DC |
| Salary type: | Annual |
| Salary: | GBP £60,000.00 |
| Location: | Woking |
| Job published: | 20-01-2026 |

| | |
|----------------|--------------------------------------|
| Job title: | Principal Power Electronics Engineer |
| Job type: | Permanent |
| Emp type: | Full-time |
| Salary type: | Annual |
| Salary: | GBP £75,000.00 |
| Job published: | 03-12-2025 |

Qualifications

- Bachelor's or Master's degree in Electrical Engineering, Power Electronics, or equivalent field.
- Minimum 5+ years of experience in design and development of power conversion systems, with emphasis on inverters and motor drives.
- Deep understanding of topologies (e.g., three-phase inverters, DC/DC converters, multilevel inverters) and related control strategies (FOC, PWM, DTC, etc.).
- Experience with SiC and GaN-based power devices and associated gate drive circuits.
- Strong analytical and modelling skills using tools like MATLAB/Simulink, PSIM, or PLECS.
- Familiarity with EMI/EMC design principles, thermal design, and safety standards (IEC, UL, ISO).
- Hands-on experience with hardware testing, lab instrumentation, and system commissioning.
- Excellent communication and cross-functional collaboration skills.

Requirements

Master's or PhD in Electrical Engineering, Power Electronics, or related field.
10+ years of experience in power electronics design, focusing on **DC/DC, AC/DC, and DC/AC conversion**.
Extensive expertise in **SiC and GaN-based power electronics** for high-efficiency designs.
Strong proficiency in **LTSpice, PLECS, MATLAB/Simulink, Altium, or similar tools**.
Experience with **high-frequency switching, EMI/EMC compliance, and thermal management**.
Hands-on experience with **PCB layout design for high-power circuits**.
Deep understanding of **control algorithms for power converters** (digital and analog).
Familiarity with **power magnetics, gate drivers, and high-voltage isolation techniques**.
Proven track record of **leading projects from concept to production**.

Why Power Electronics?

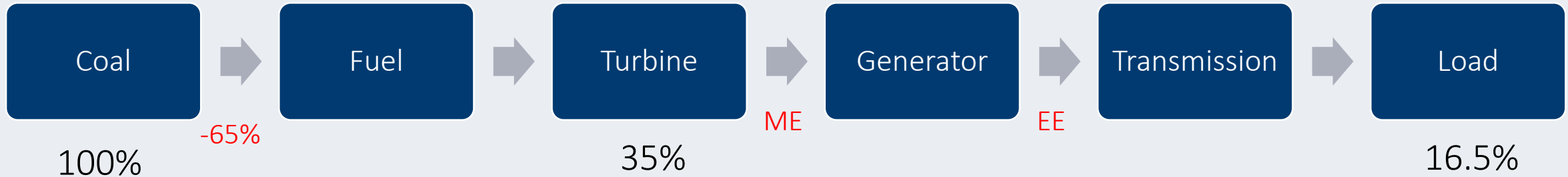

- Fossil fuel (Oil, natural gas and coal) still the most used energy source, >85%.
- In best scenarios, the fossil fuel energy sources will last for +150 years
- What will happen after 150 years ? We don't know

But we can extend this period or even replace the traditional resources by:

1. Using it efficiently → Global warning still a problem
2. Improve the energy conversion efficiency
3. Promote more integrated renewable energy sources

} Role of Power Electronic circuits

Why Power Electronics?

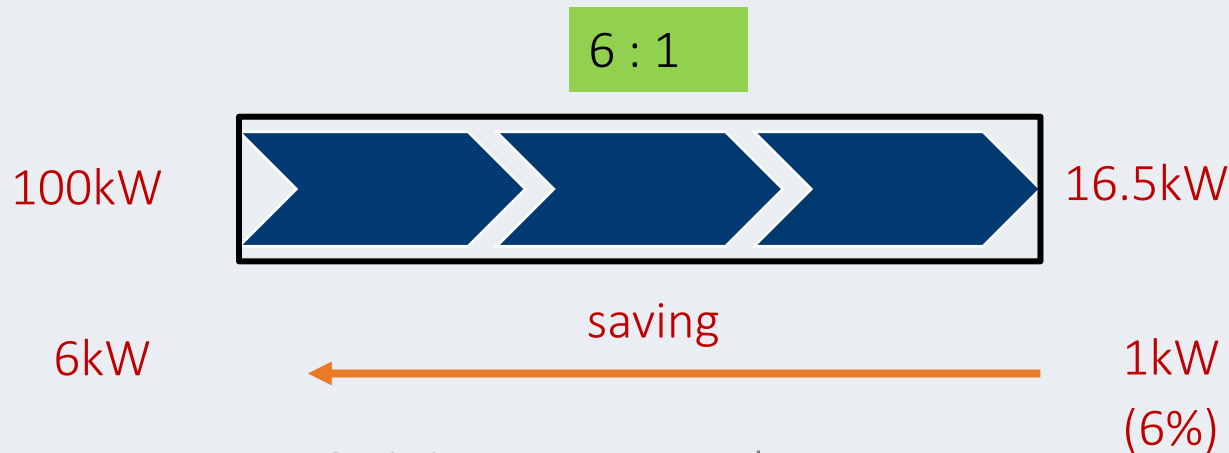
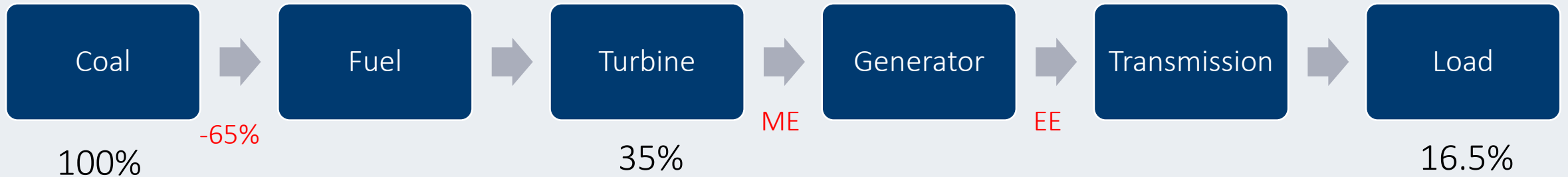

Why do we spend effort on the load side (i.e. Motor efficiency) when most of losses are at front end ?

So it is necessary to have higher efficiency drives, chargers and circuits for the loads Done by PE.

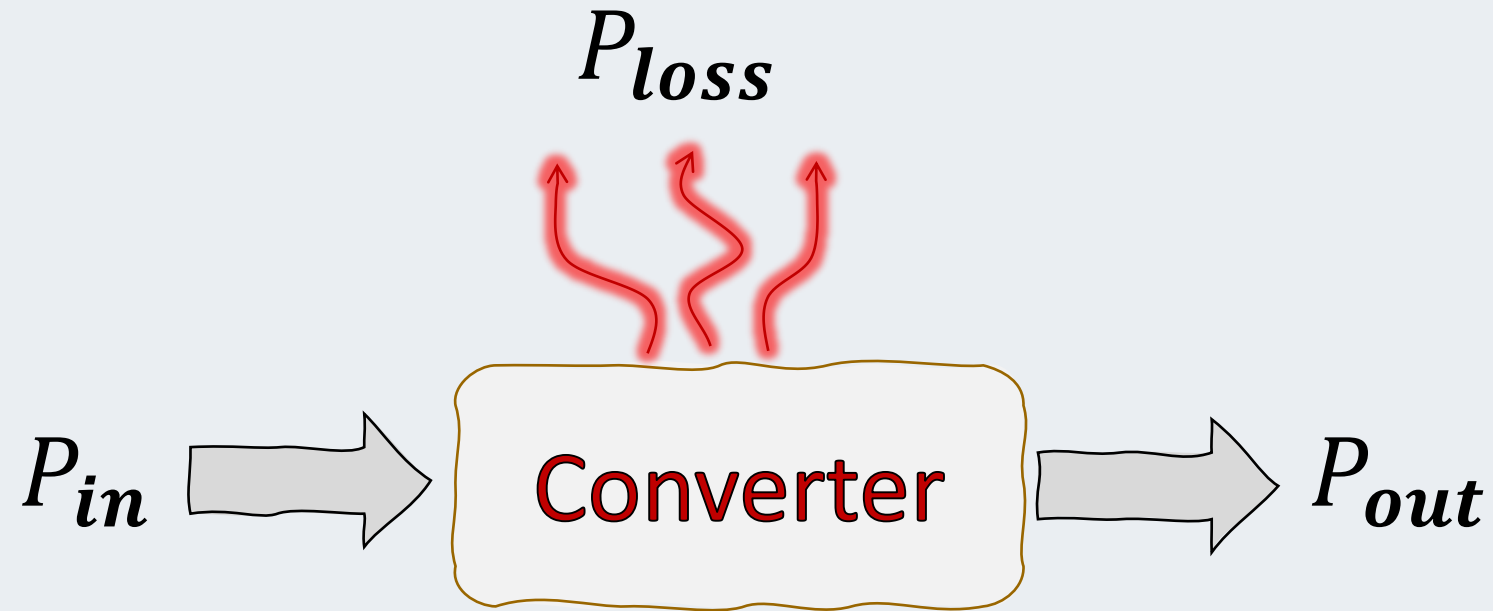

$$\eta = \frac{P_{out}}{P_{in}}$$

$$P_{in} = P_{out} + P_{loss}$$

$$\eta = \frac{P_{out}}{P_{out} + P_{loss}}$$

$$\eta(P_{out} + P_{loss}) = P_{out}$$

$$P_{out} = \frac{\eta}{1 - \eta} P_{loss}$$

$$P_{out} = \frac{\eta}{1 - \eta} P_{loss}$$

$$P_{loss} = 1 \text{ kW}$$



→ $P_{out1} = \frac{0.85}{1 - 0.85} \times 1k = 5.7kW$

$$P_{loss} = 1 \text{ kW}$$

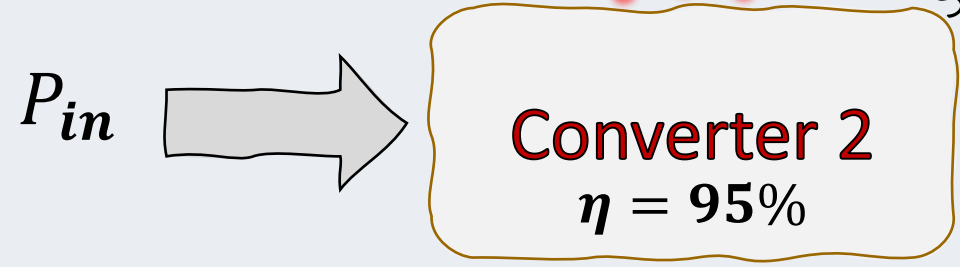

Same size

→ $P_{out2} = \frac{0.95}{1 - 0.95} \times 1k = 19 \text{ kW}$

+3

Higher Efficiency

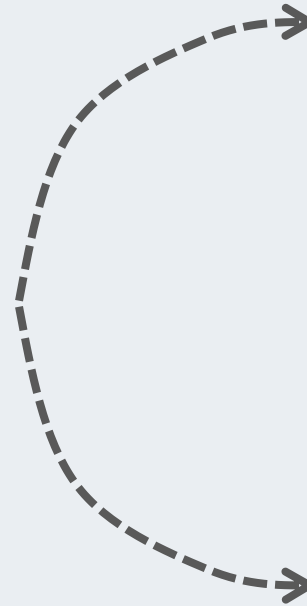

Switches

Diodes, transistors, thyristors

Silicon, Silicon Carbide, GaN

Topologies

Interleaving, switched capacitors, etc

Hard and soft switching

Power Semiconductor Devices

The power semiconductor devices are used as on/off switches in power control circuit. These devices are classified as follows.

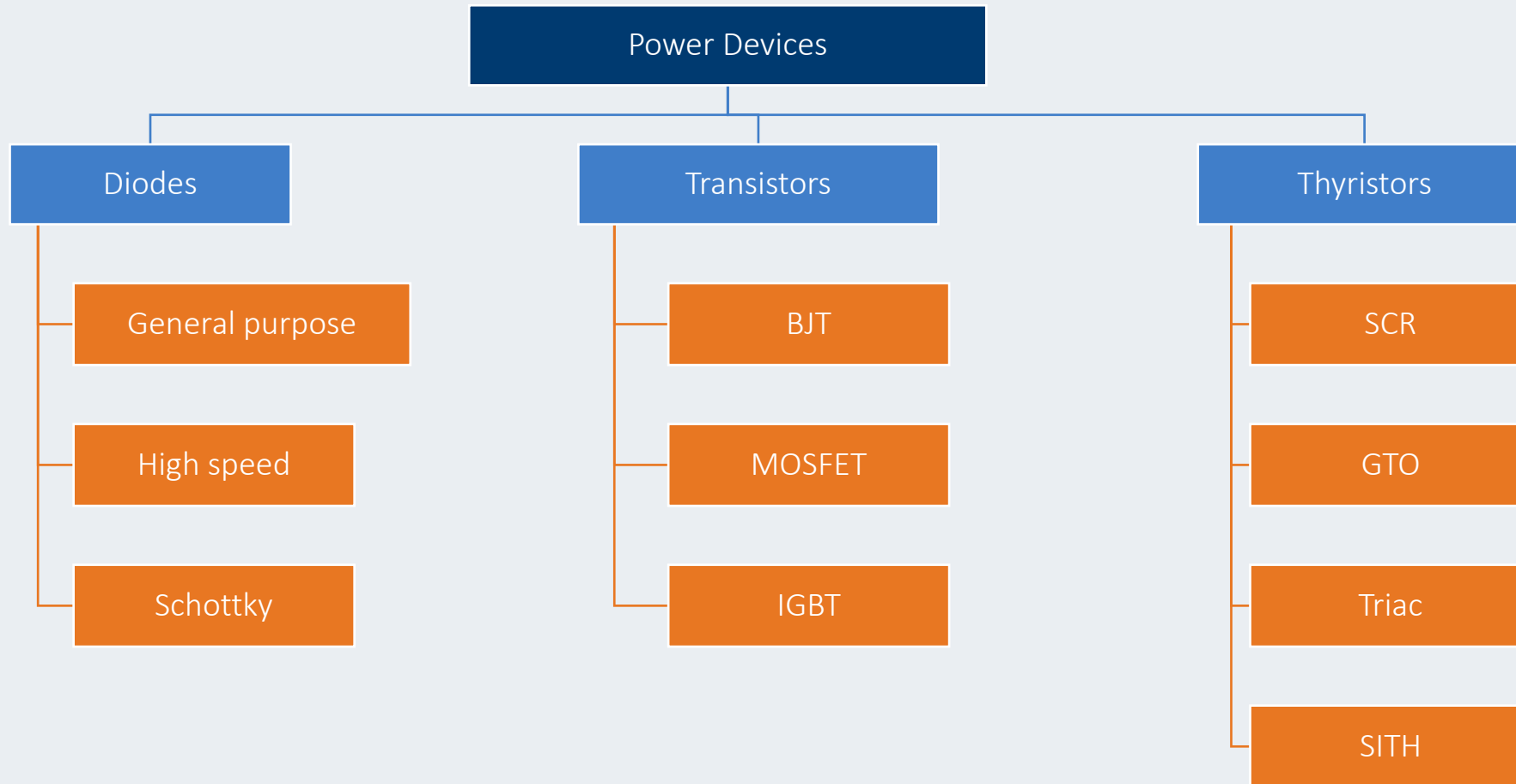

Power Semiconductor Topologies

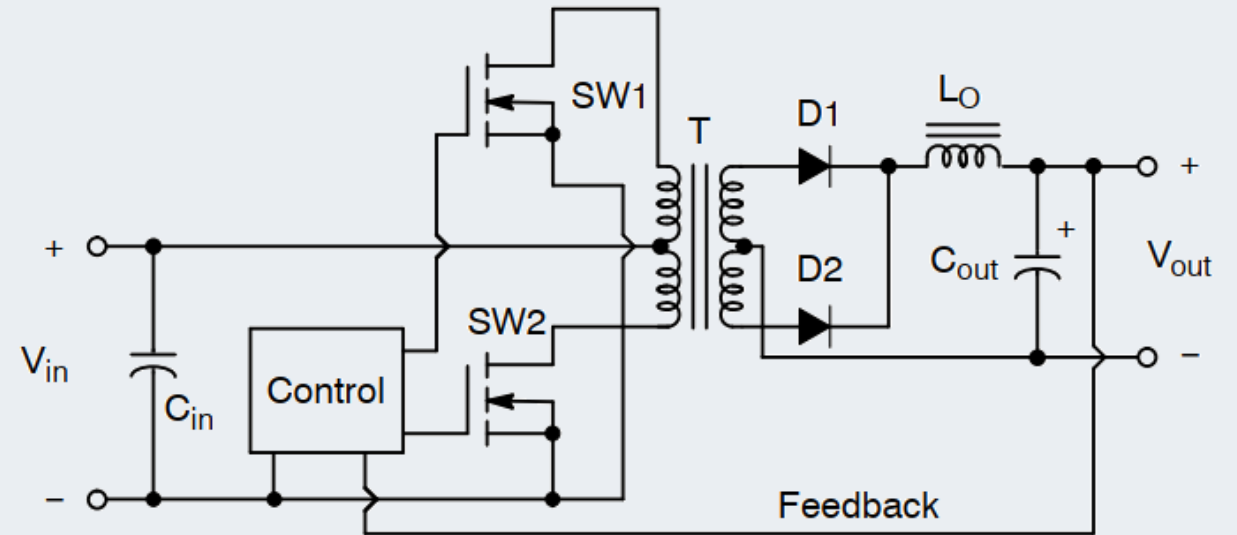
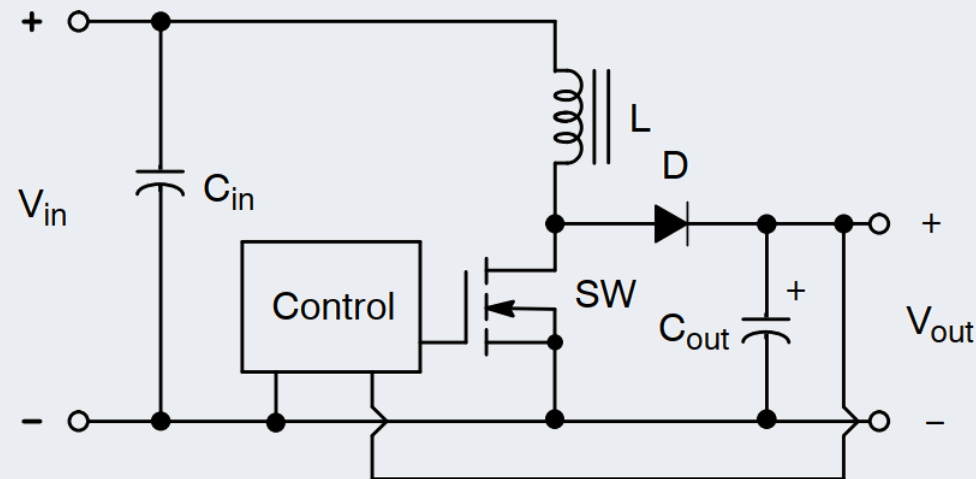
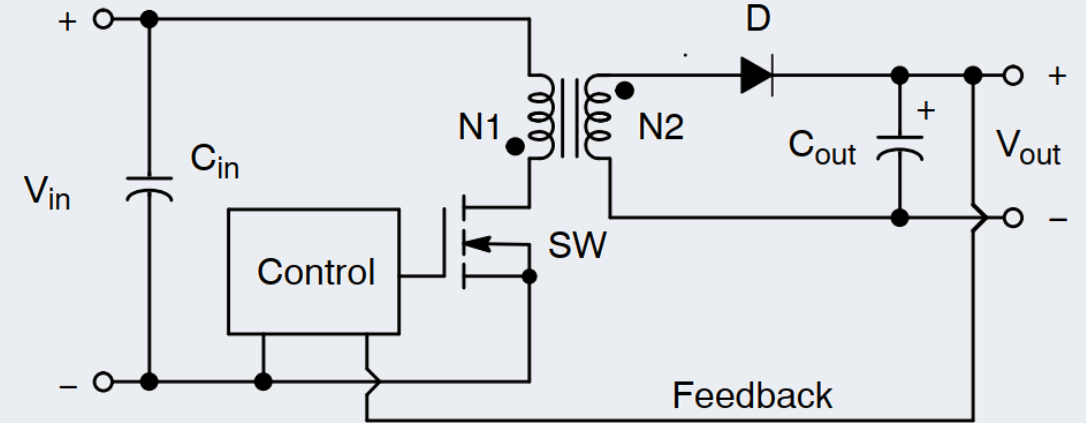
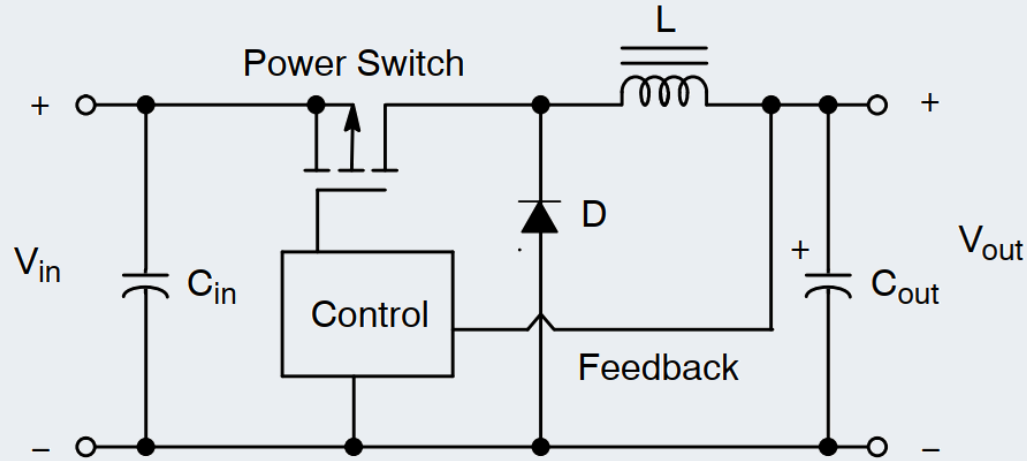

Power Semiconductor Devices

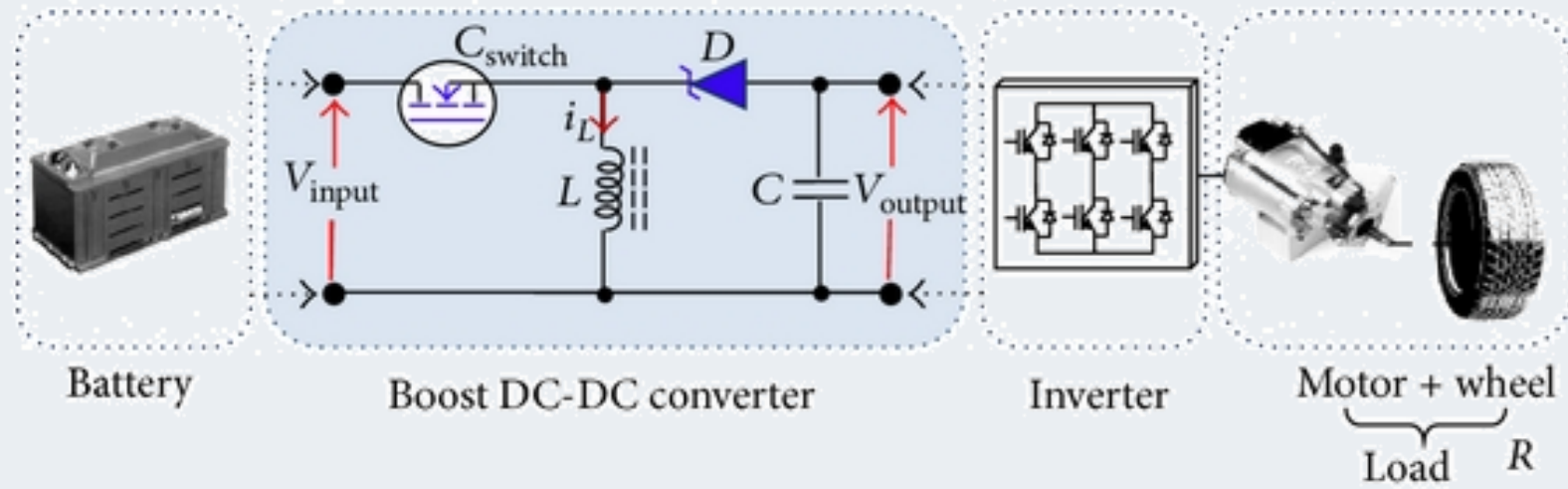
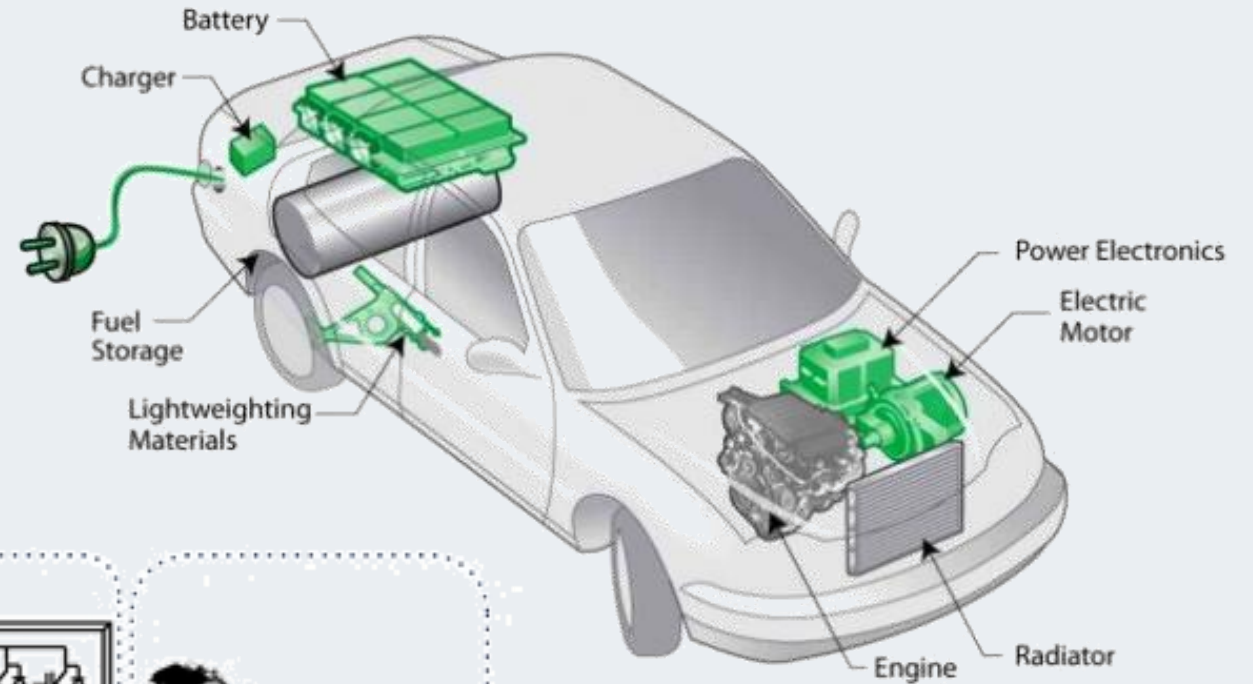

Why Pulse Width Modulation (PWM)

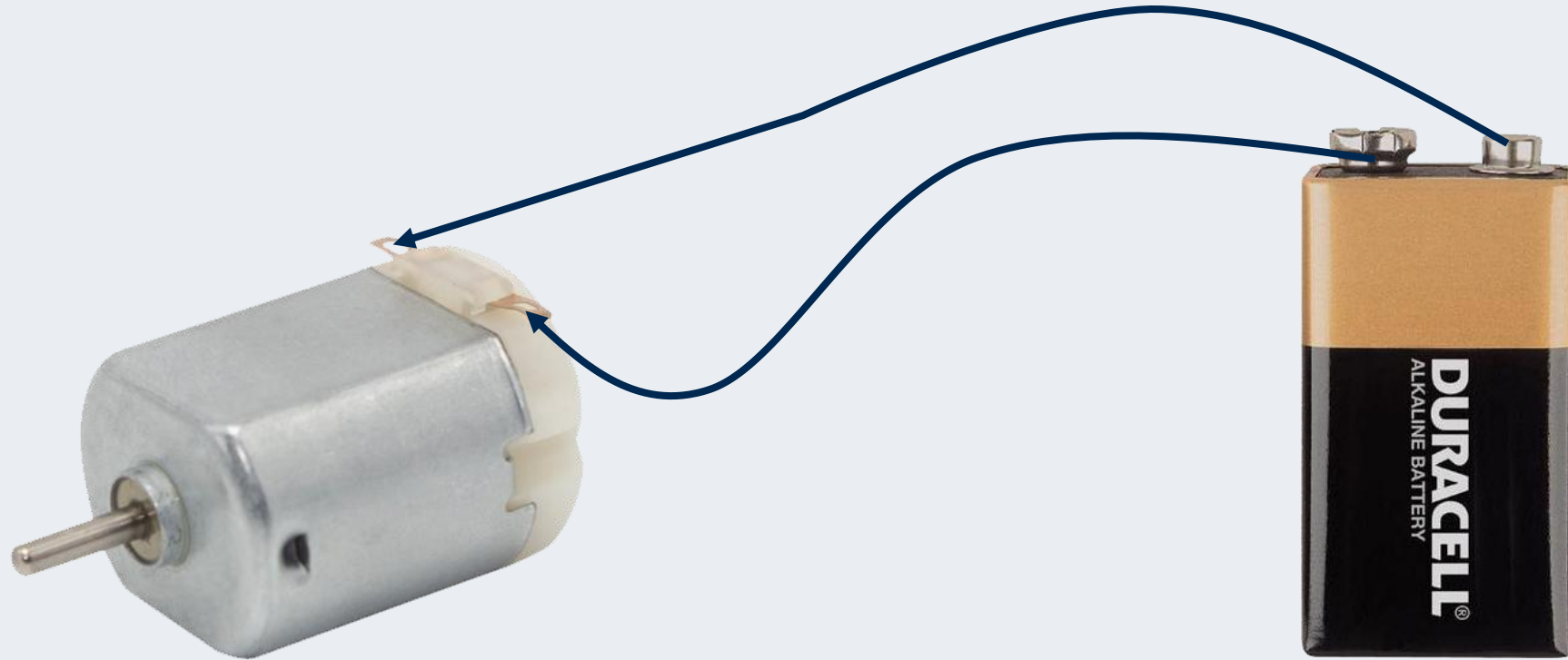

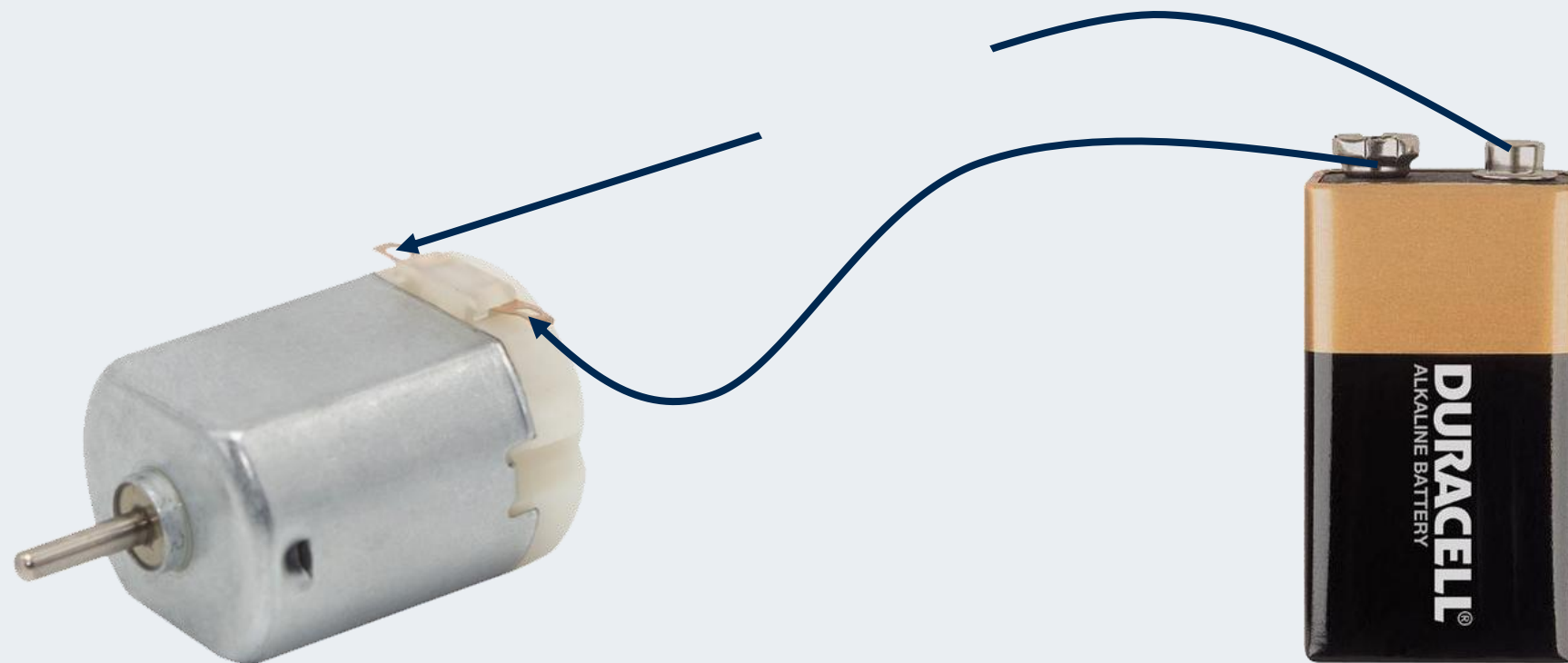

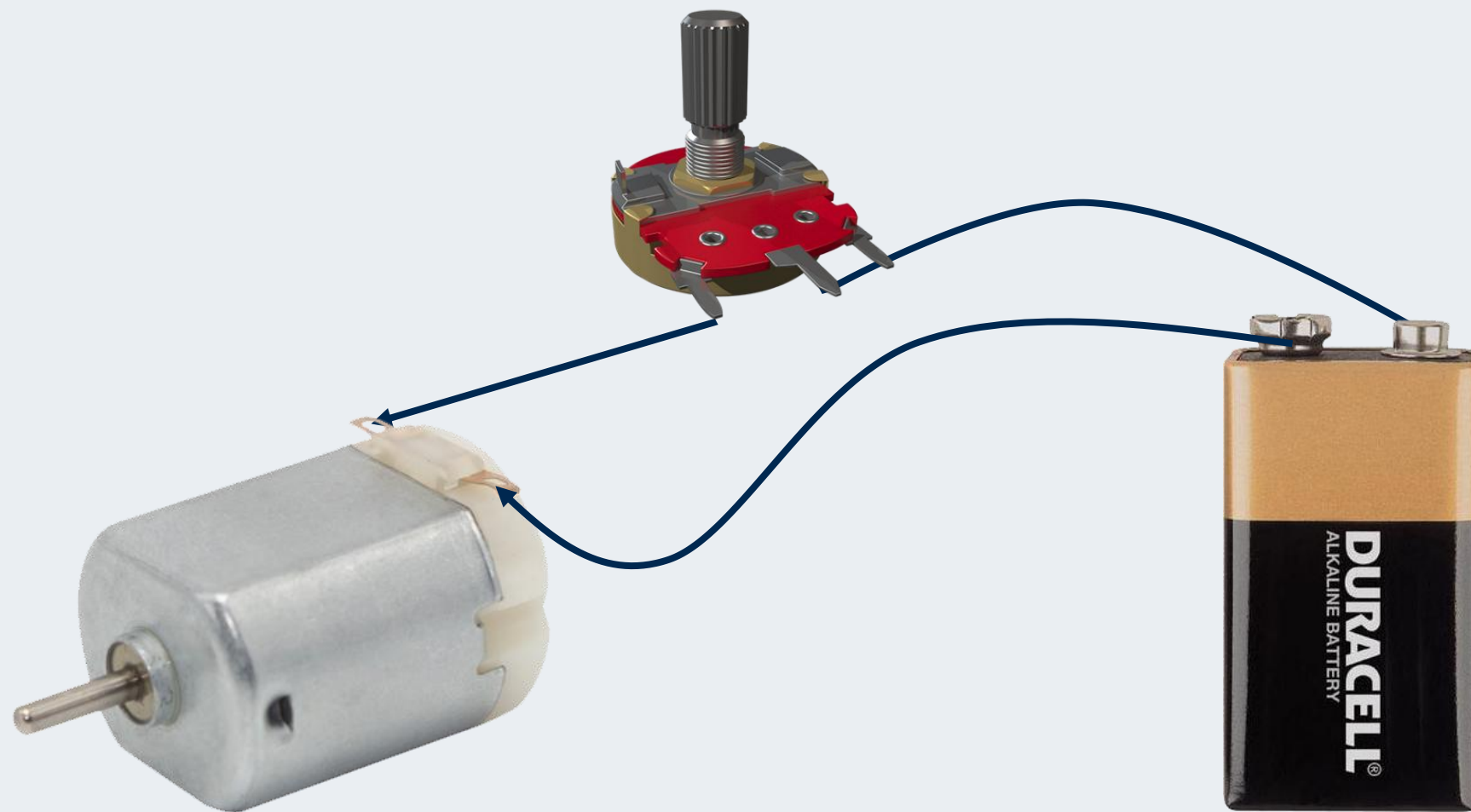

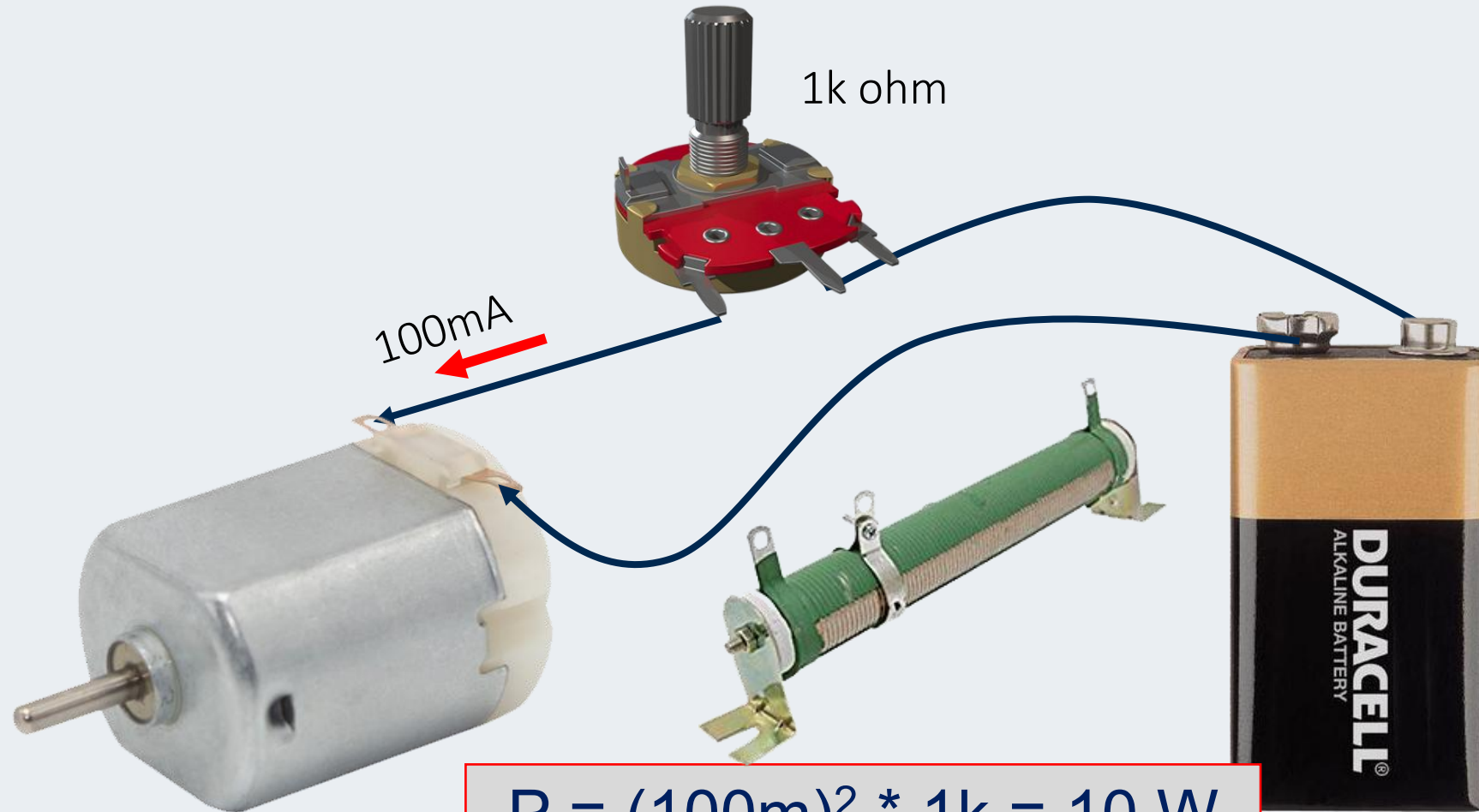

$$P = (100\text{m})^2 * 1\text{k} = 10 \text{ W}$$

$$P = (1)^2 * 100 = 100 \text{ W}$$

Linear operation

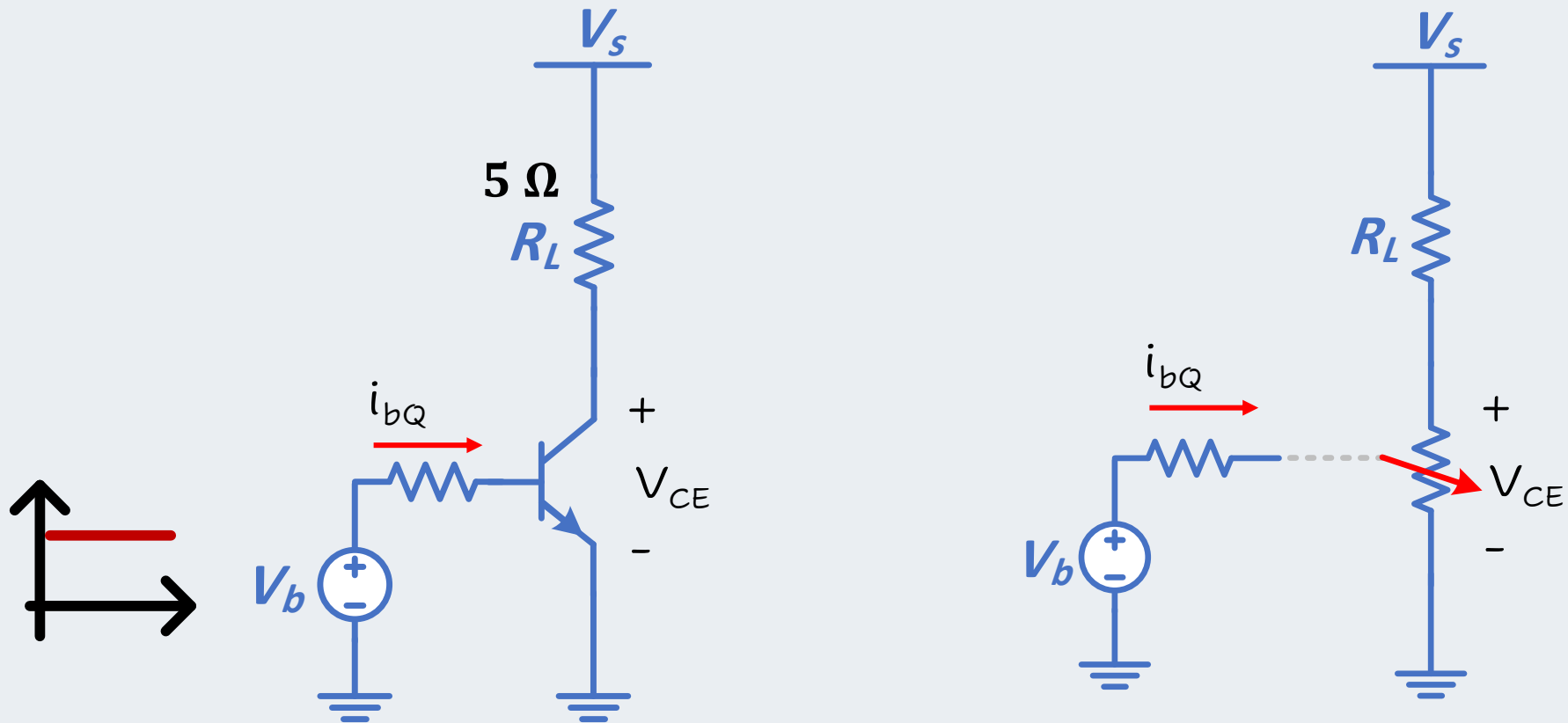

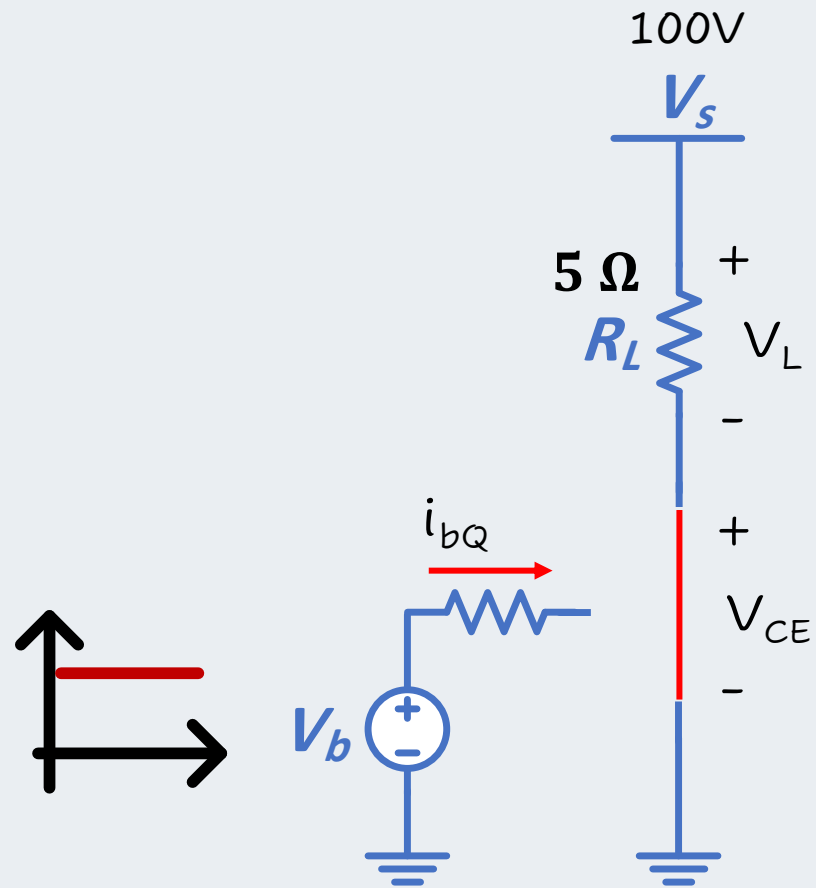

Linear operation

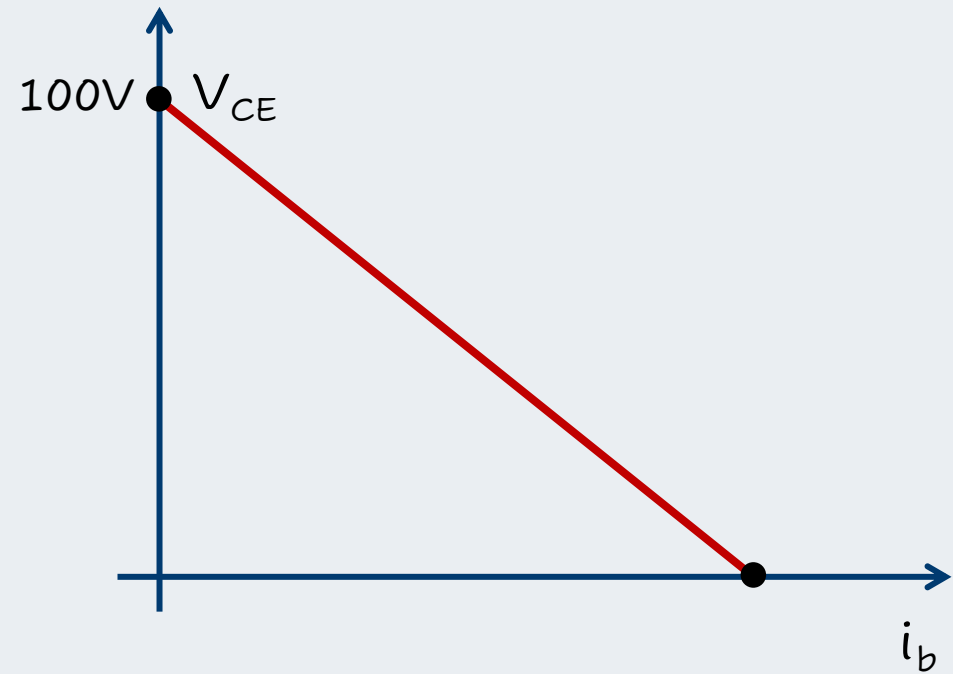

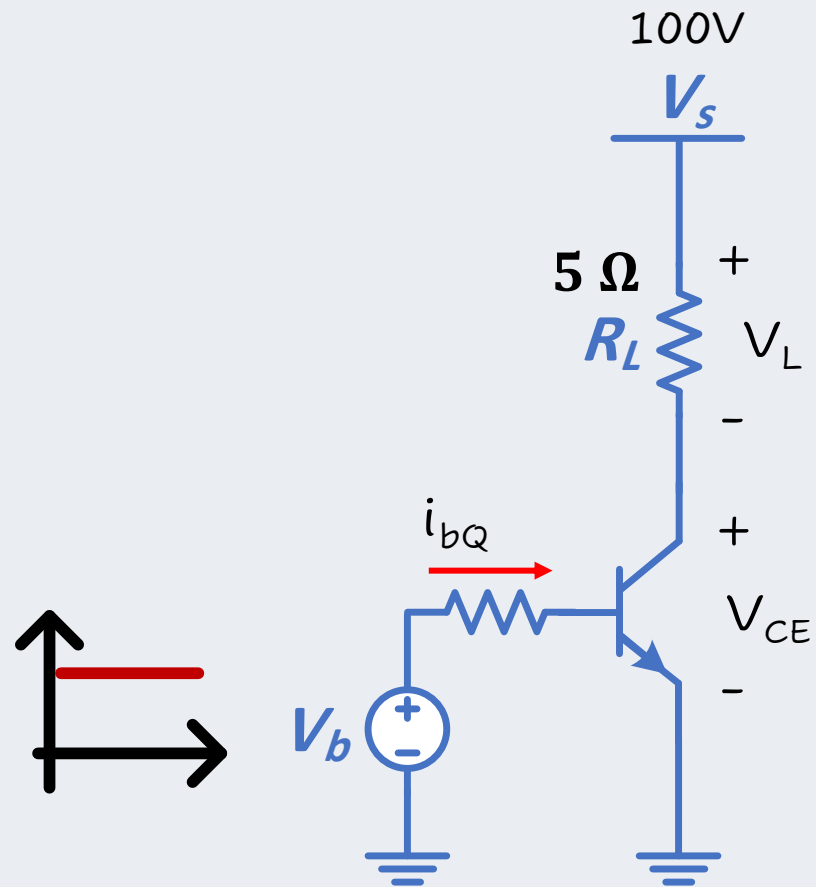

Linear operation

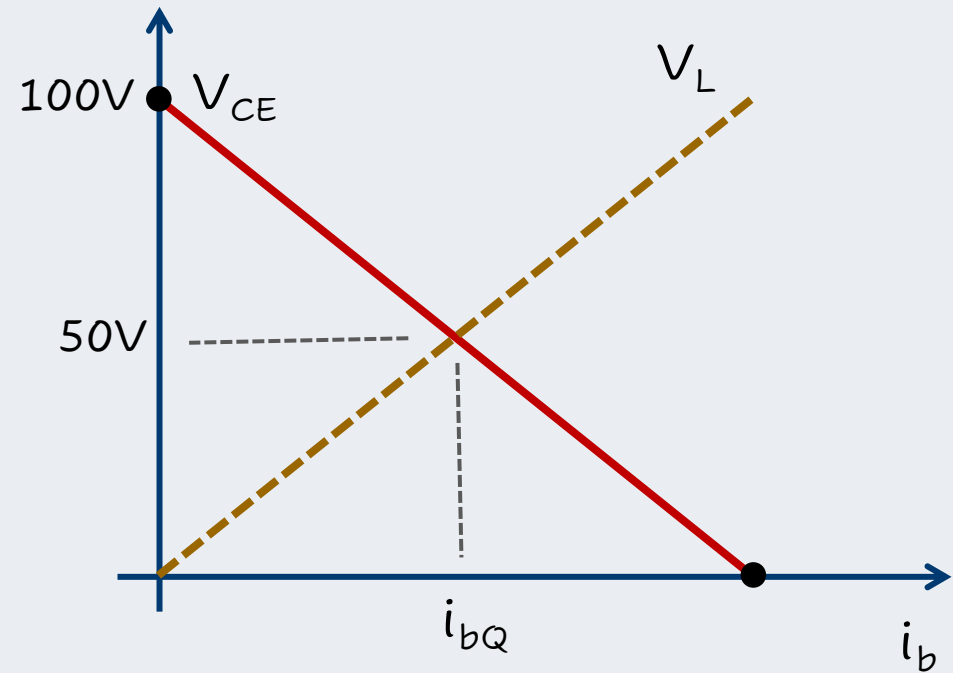

$$I_C = \frac{50}{5} = 10A$$

$$P_t = V_{CE} \times I_C$$

$$P_t = 50 \times 10 = 500W$$

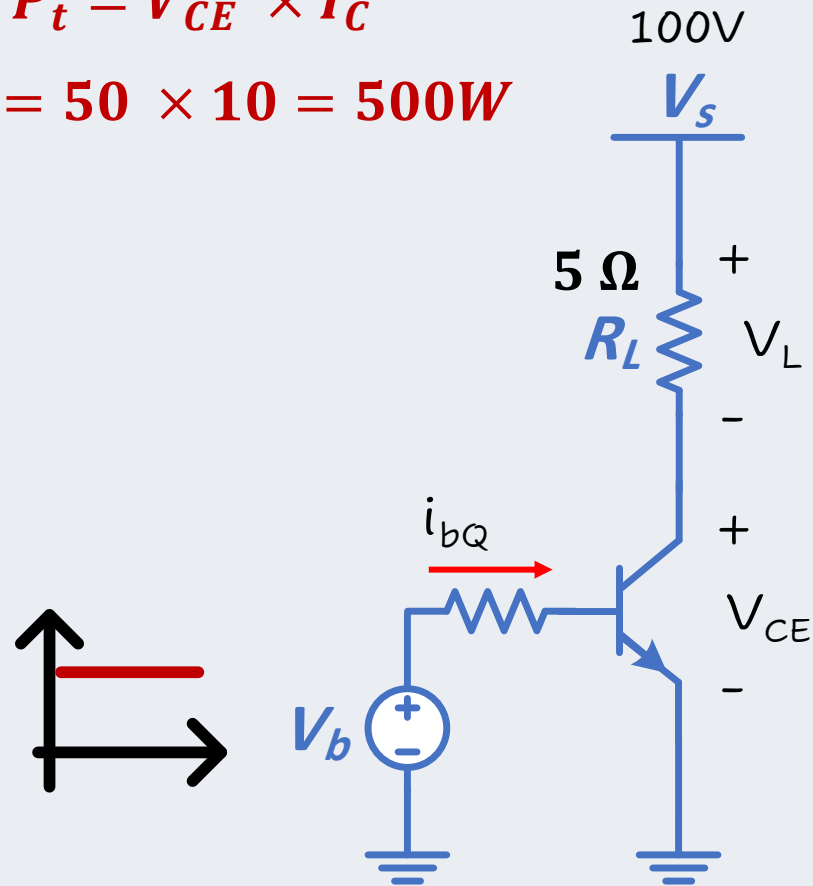

Linear operation

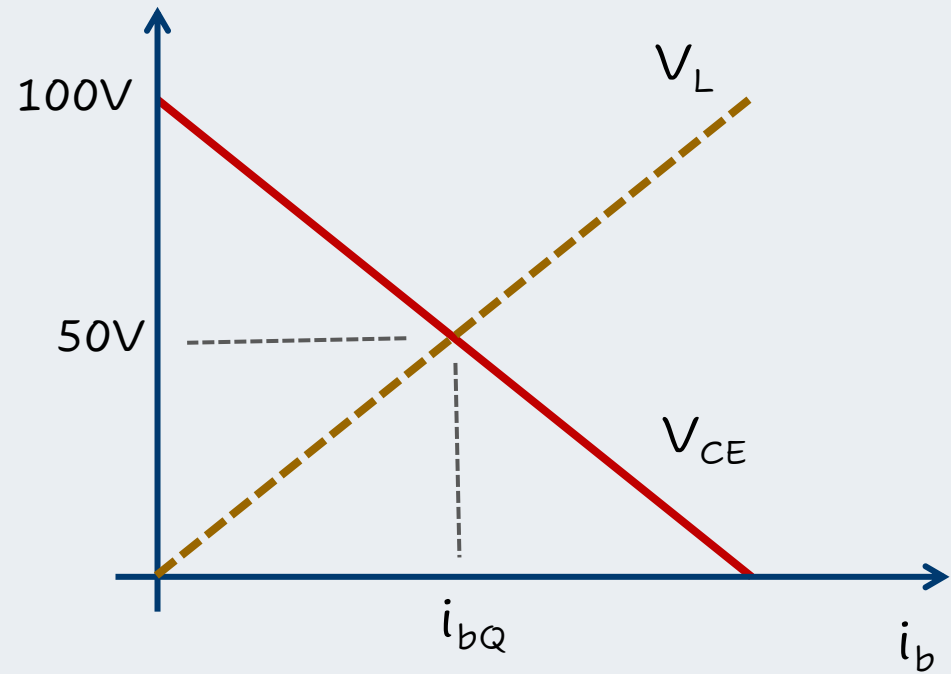

What is the PWM ?



Voltage

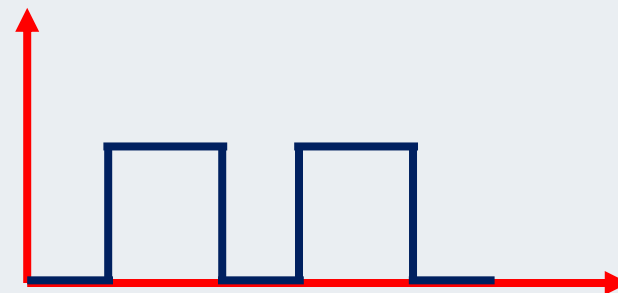

Pulse Width Modulation ?

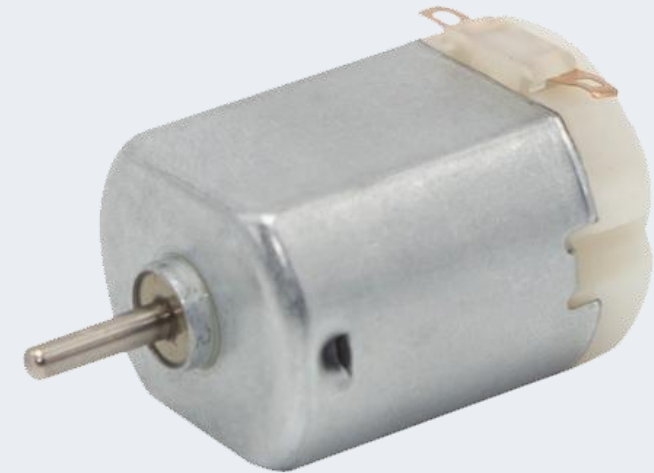

Average (mean) value

What is the PWM ?

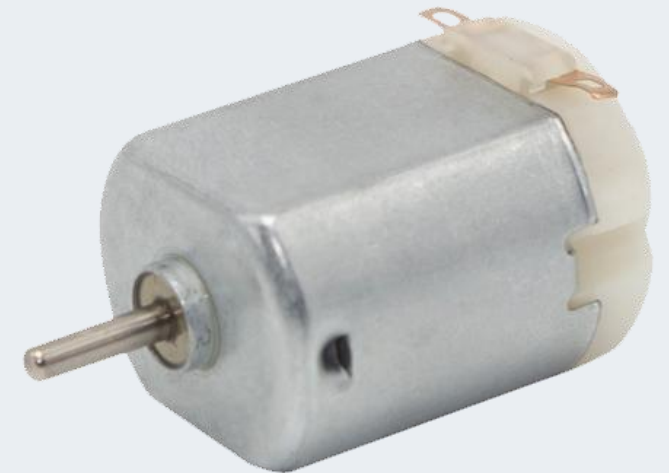
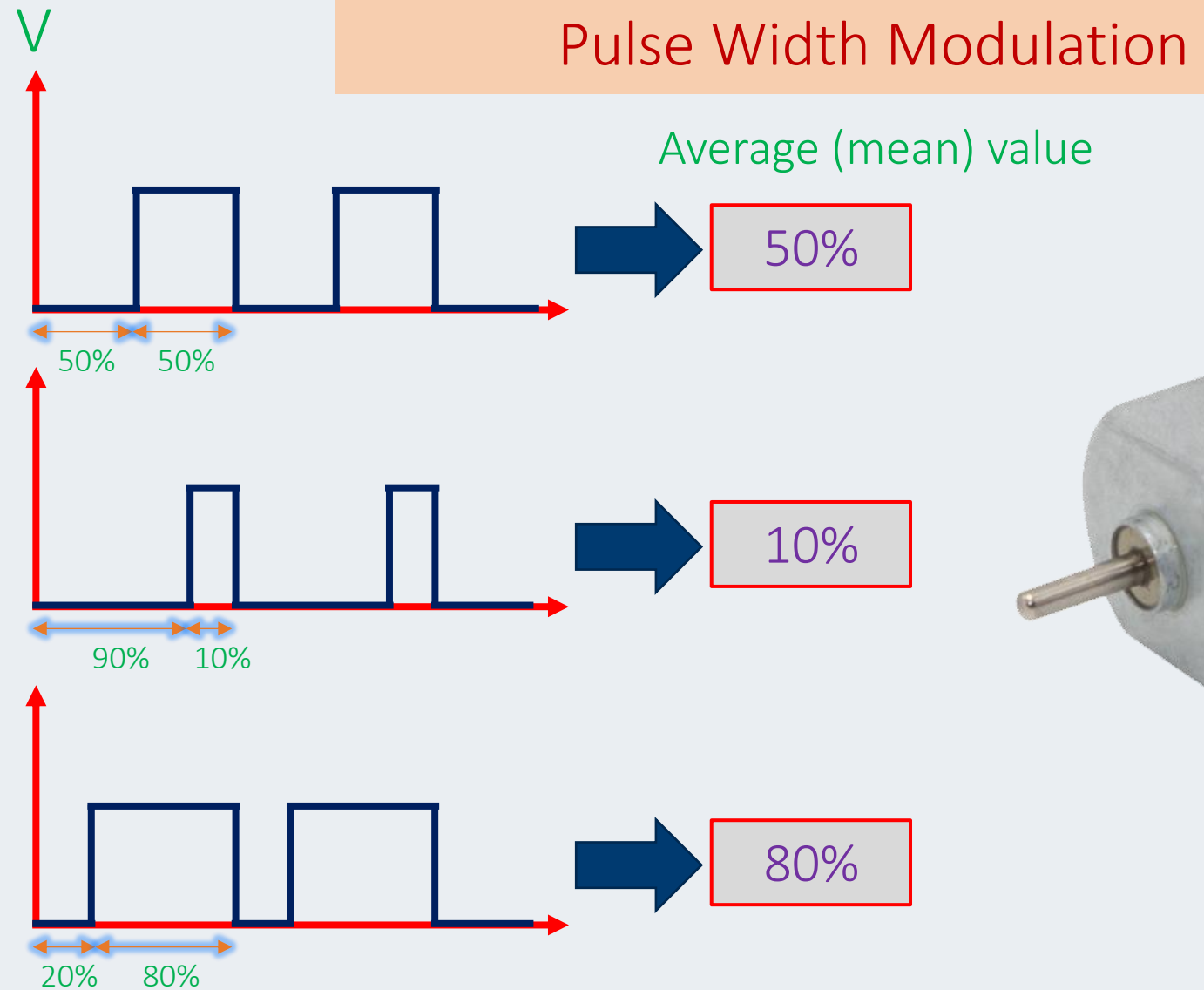

What is the PWM ?

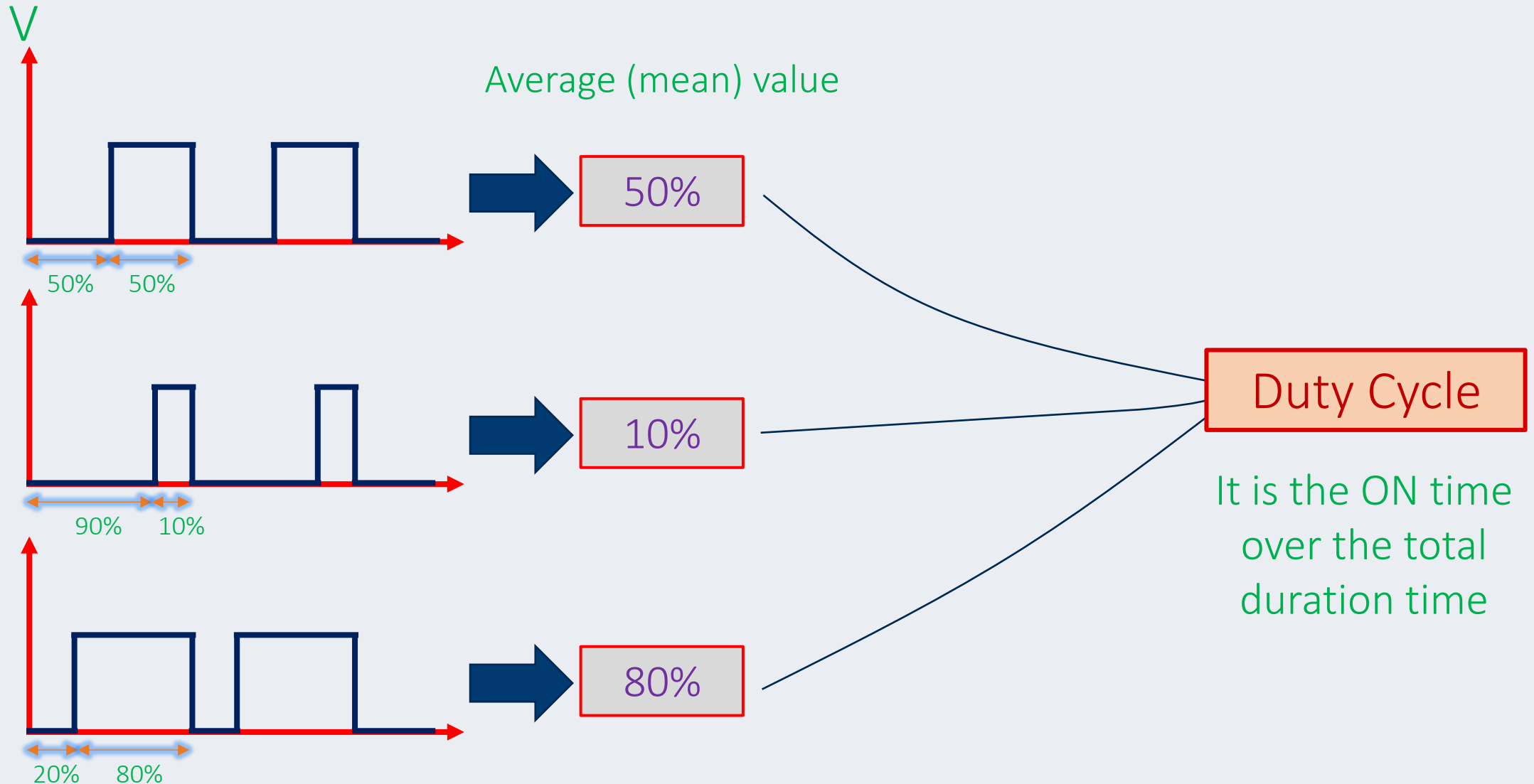

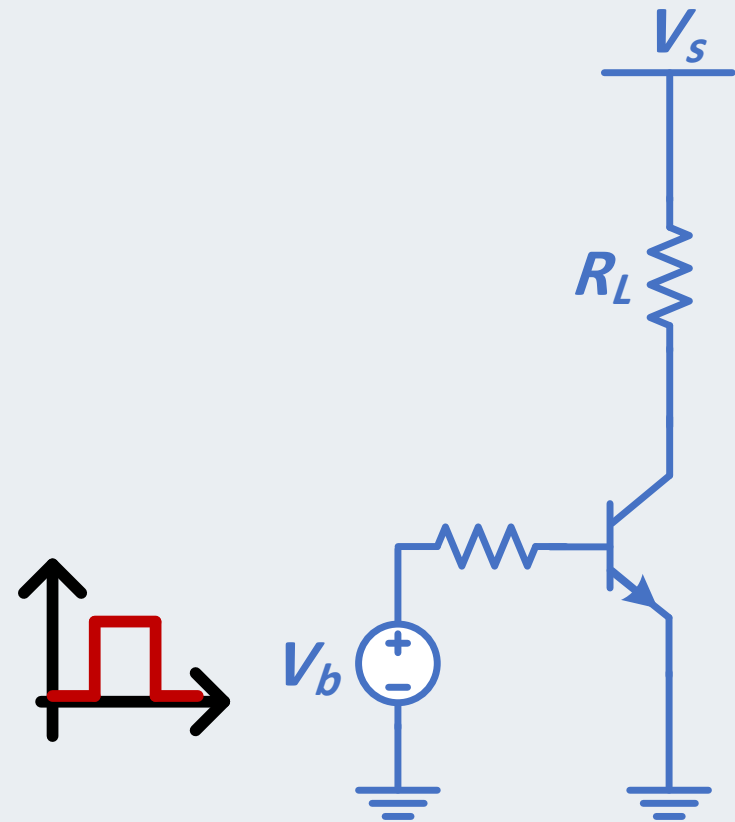
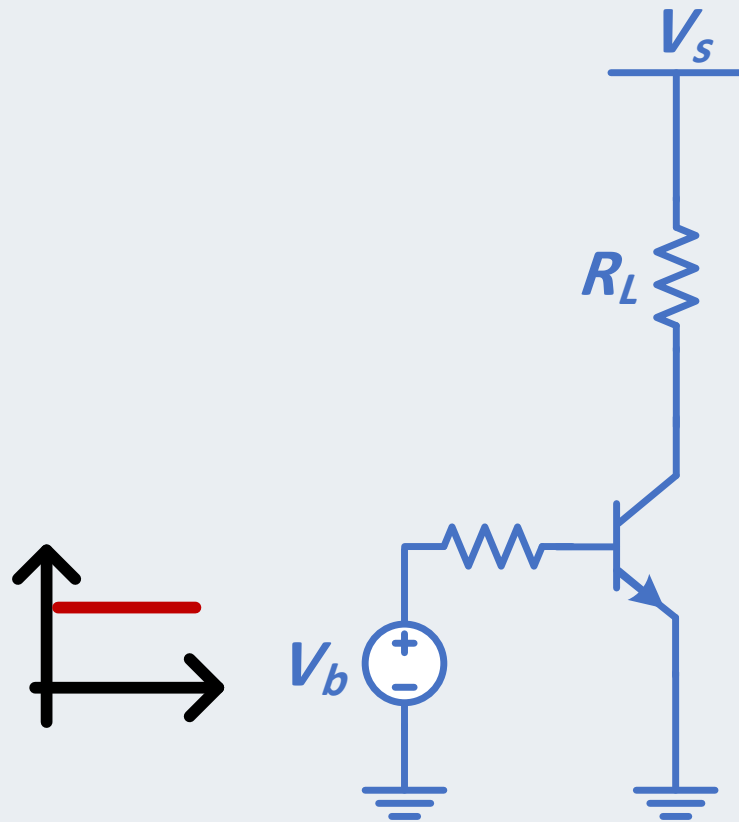

Switched operation

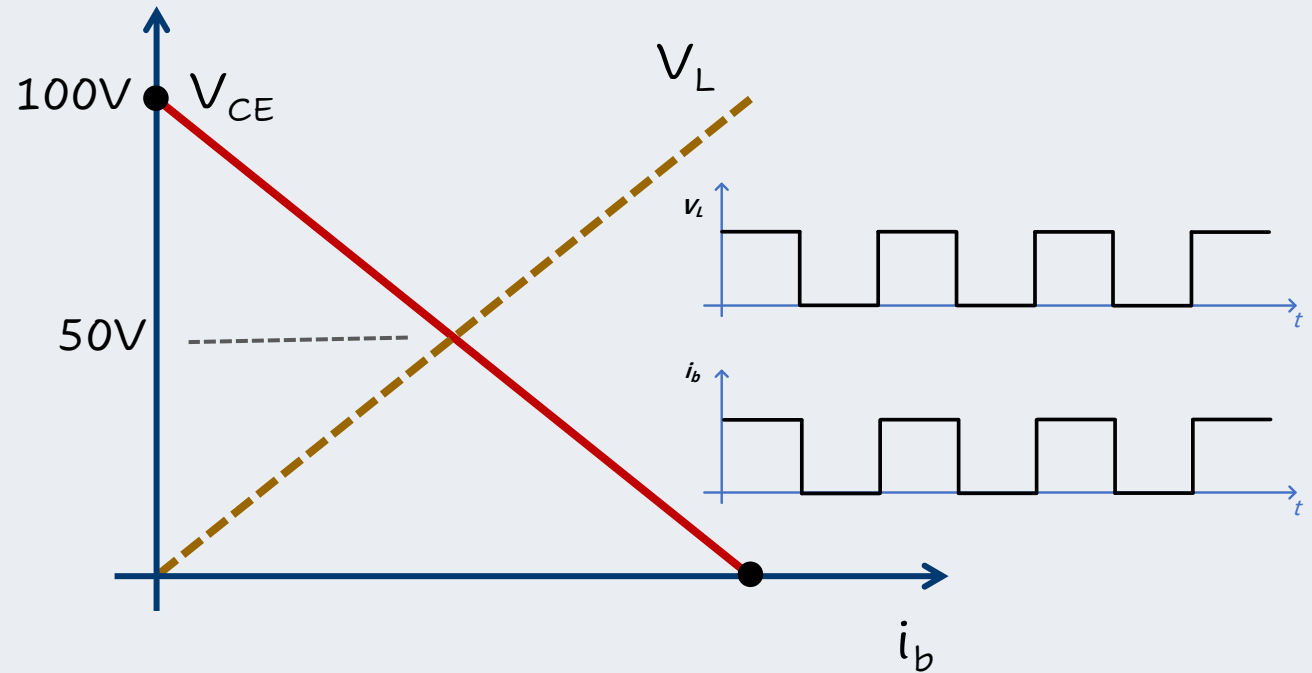
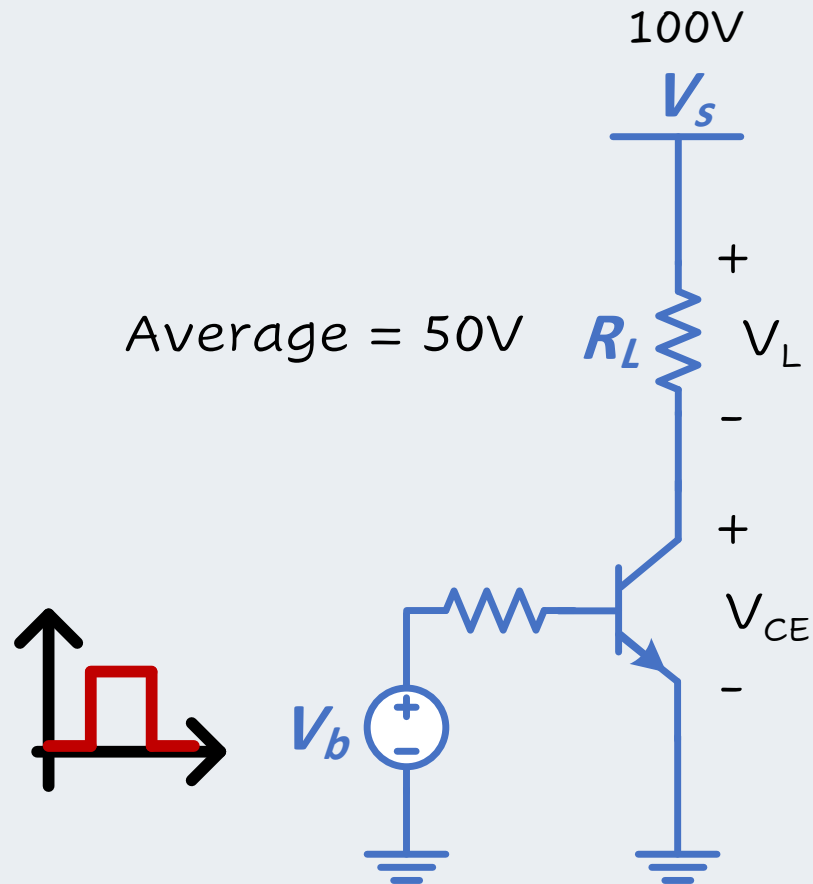

Dissipated power in transistor

Linear operation

$$I_C = \frac{50}{5} = 10A$$

$$P_t = V_{CE} \times I_C$$

$$P_t = 50 \times 10 = 500W$$

Switched operation

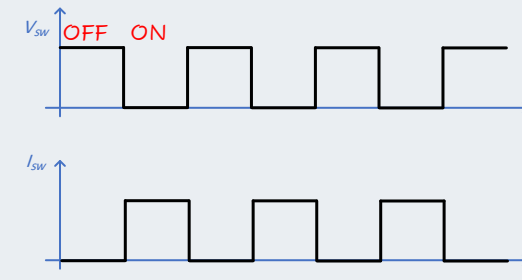

$$P_t = V_{CE} \times I_C$$

ON state $p_t = 0 \times 20 = 0W$

OFF state $p_t = 100 \times 0 = 0W$

Average $P_t = 0W$

$$P_t = \int_0^T V_{CE} \times I_C dt = 0W$$

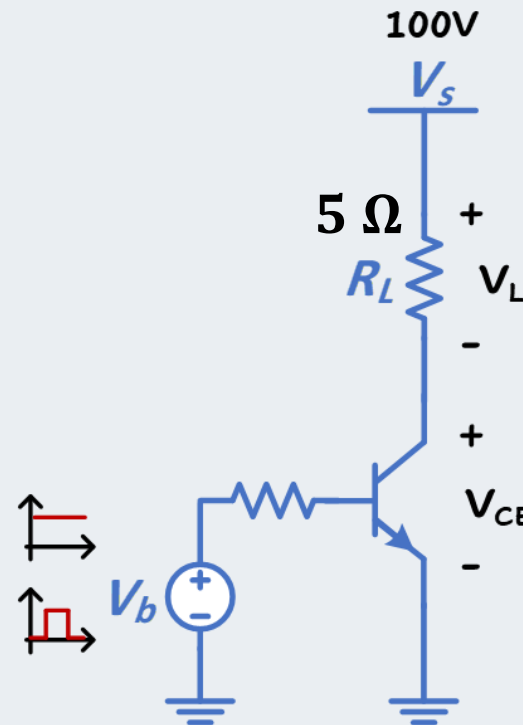

Power Switches

The switches can be controlled by either

Passive The switch state depends on the polarity of the voltage across its terminals, or the current flowing through it

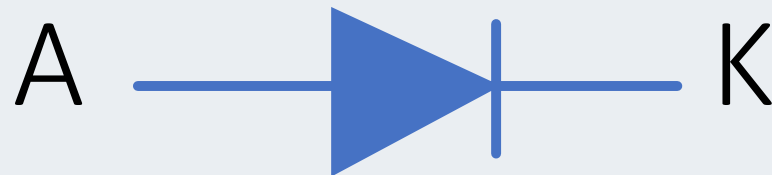

Uncontrolled

Diodes

$$V_A > V_K$$

Power Switches

The switches can be controlled by either

Active The switch state depends on some control signal applied on its terminal to control the conduction through it.

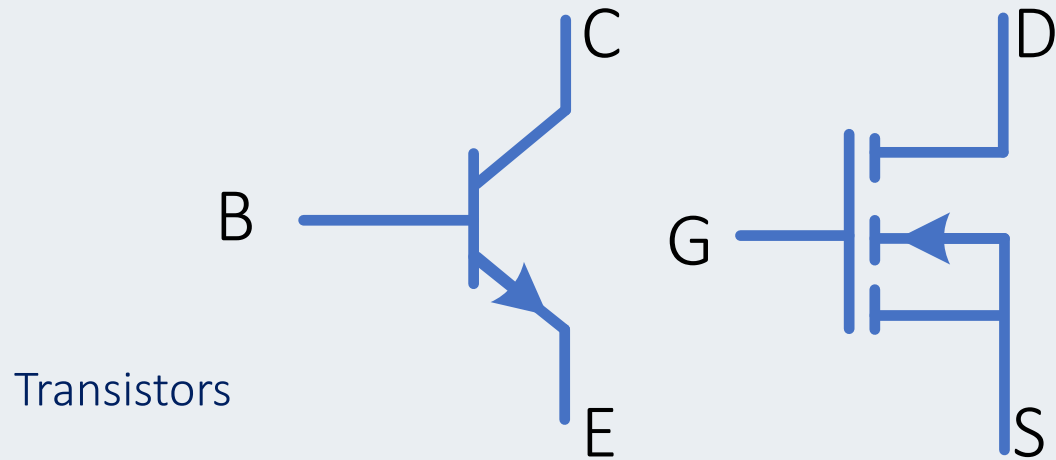

Transistors

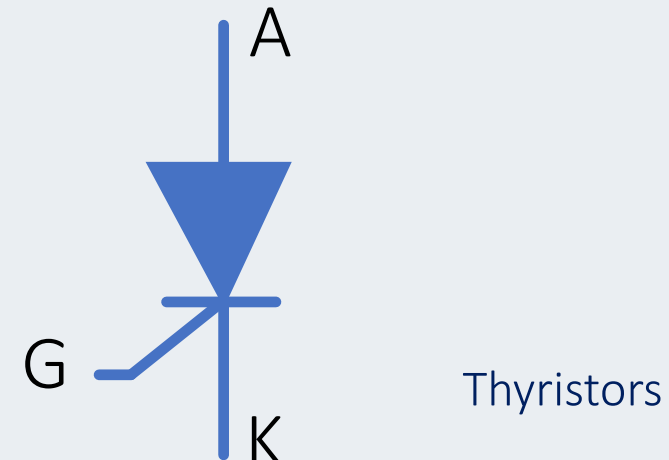

Thyristors

Fully-Controlled

Semi-Controlled

Ideal Switches



ON $V_{on} = 0$
 $-\infty < i_{on} < \infty$

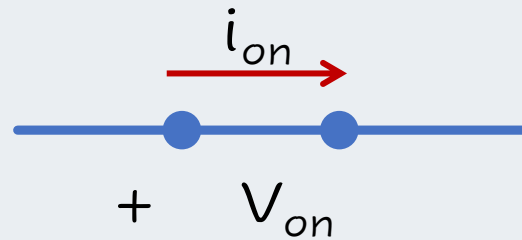

OFF $-\infty < V_{off} < \infty$
 $i_{off} = 0$

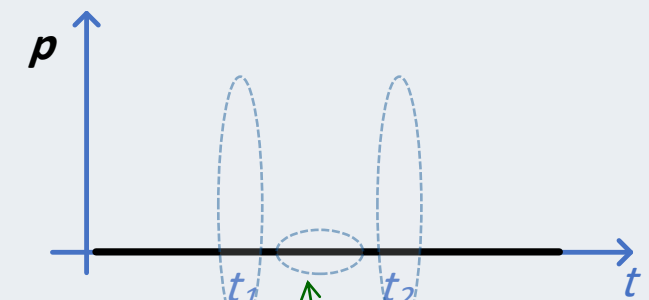
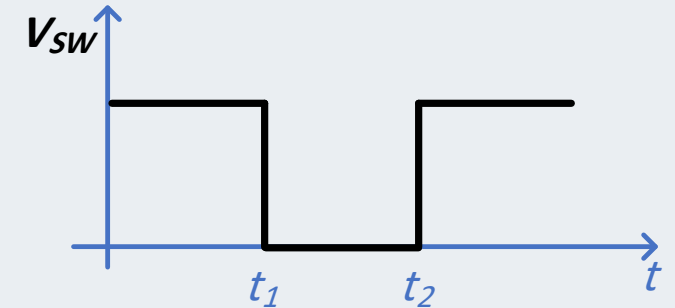
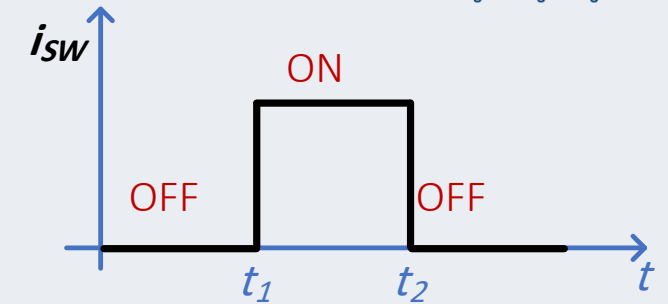
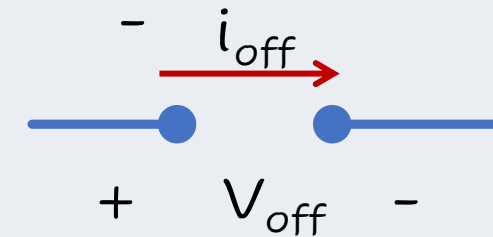

Switching ON losses
 Switching OFF losses
 Conduction losses

Power Loss = Switching losses + Conduction Losses

Practical Switches

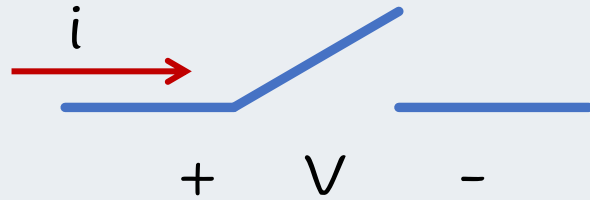

ON

$$V_{on} \neq 0$$

$$i_{on} < I_{max}$$

OFF

$$V_{off} < V_{max}$$

$$i_{off} \neq 0$$

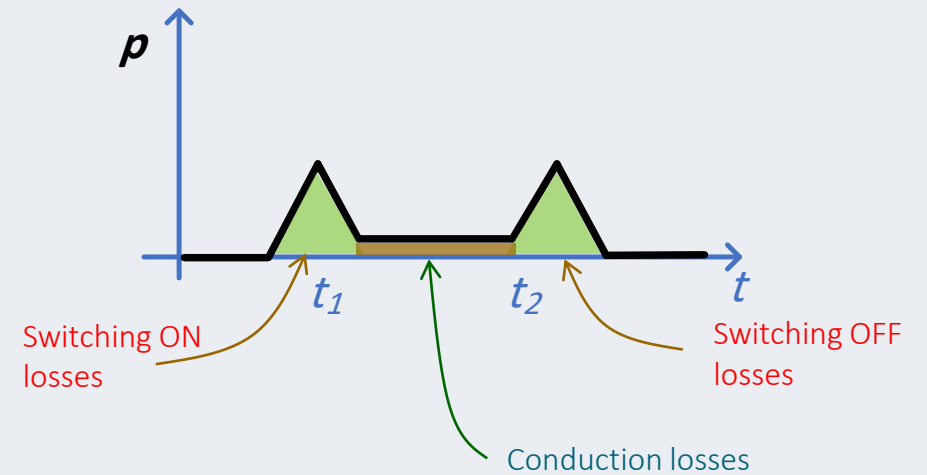
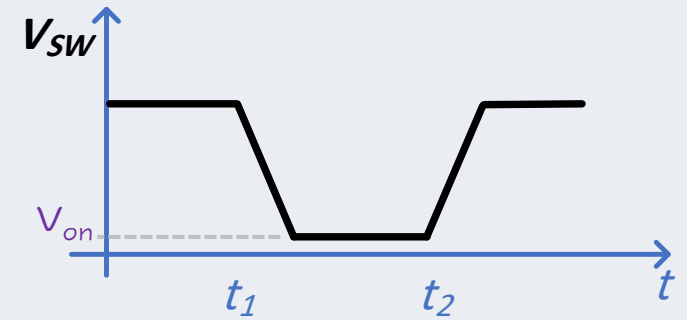
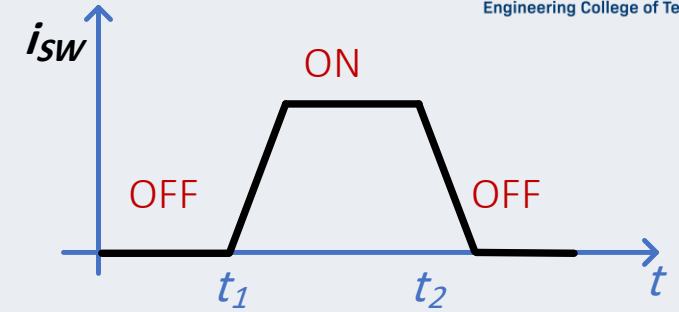
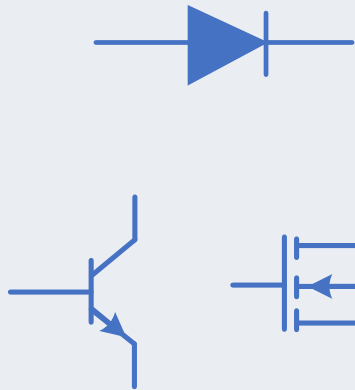

Power Loss = Switching losses + Conduction Losses

Practical Switches

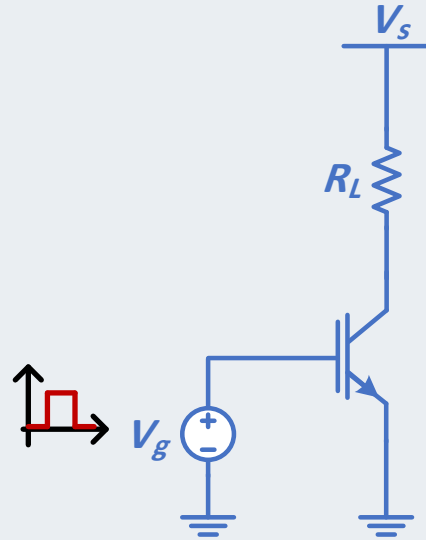

The delay time (t_d) corresponds mainly to the charging of the base-emitter junction diffusion capacitance or V_{th} and gain for the Mosfet

The current rise/fall time (t_r , t_f) is related to the effective base zone width and, as the base charge increases because of the base current, the collector current increases

t_s : The period after the cessation of positive base current until the transistor enters the linear region is termed storage or saturation time, because of overdriving.

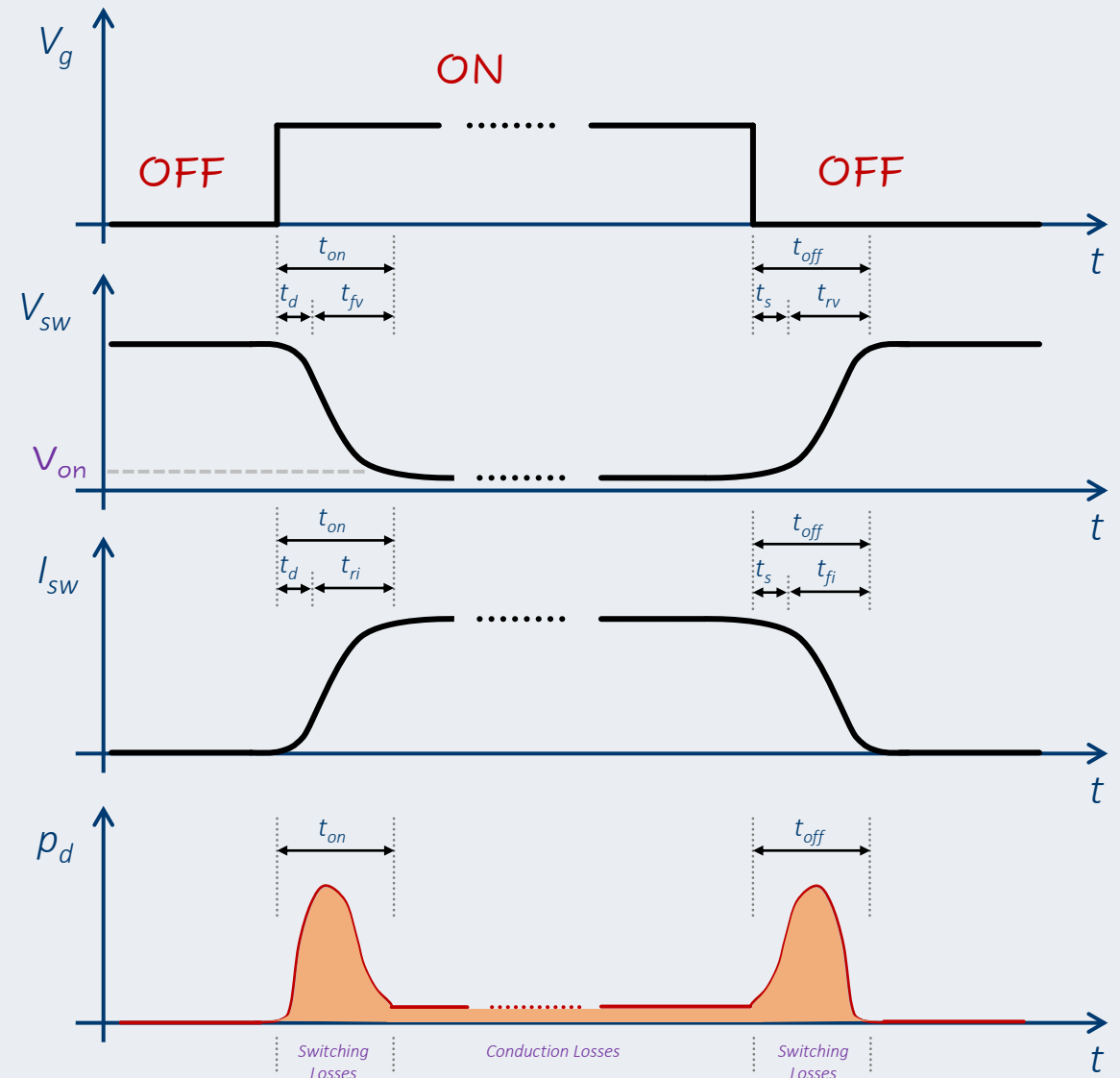

Power Diodes

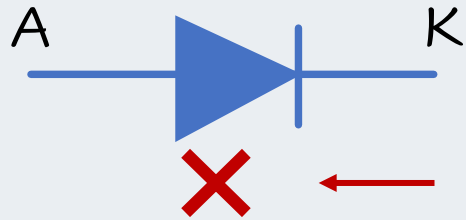

$$V_A < V_K$$

Reverse bias

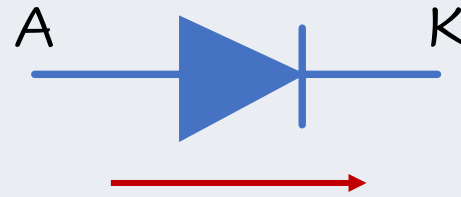

$$V_A > V_K$$

Forward bias

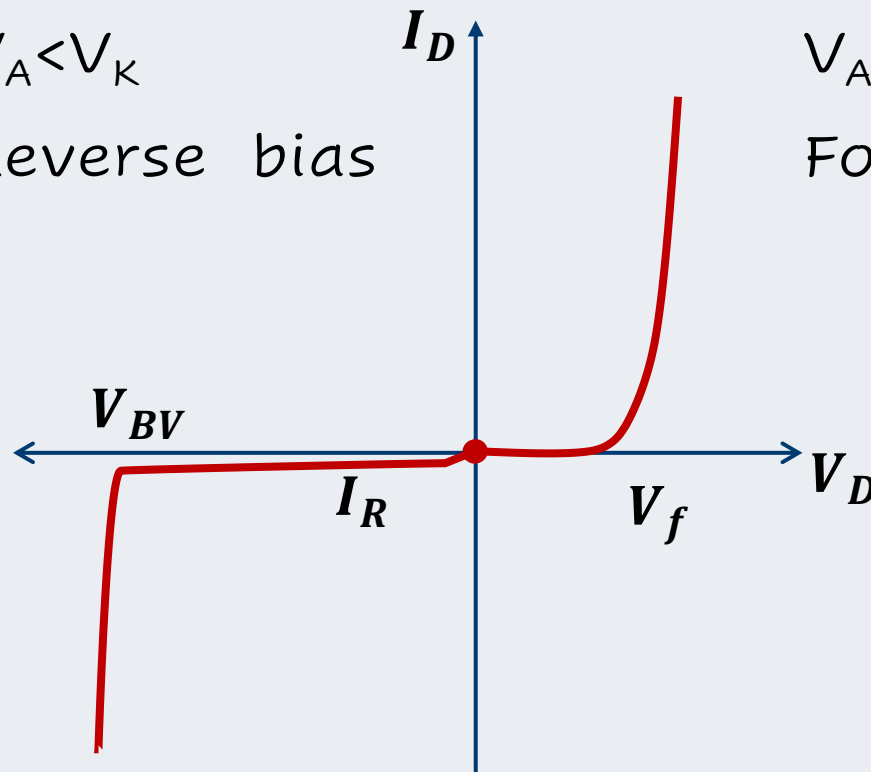

Diode-specific Electrical Characteristics

- * V_F : Forward voltage
- * I_R : Reverse current (leak current)
- * C_t : Capacitance
- * T_{rr} : Reverse recovery time

Power Diodes

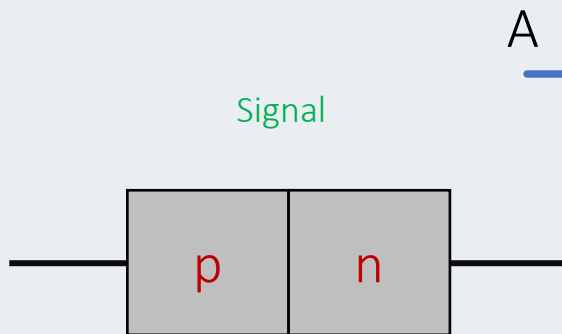

Signal

Low currents
Low Blocking voltages
Low power

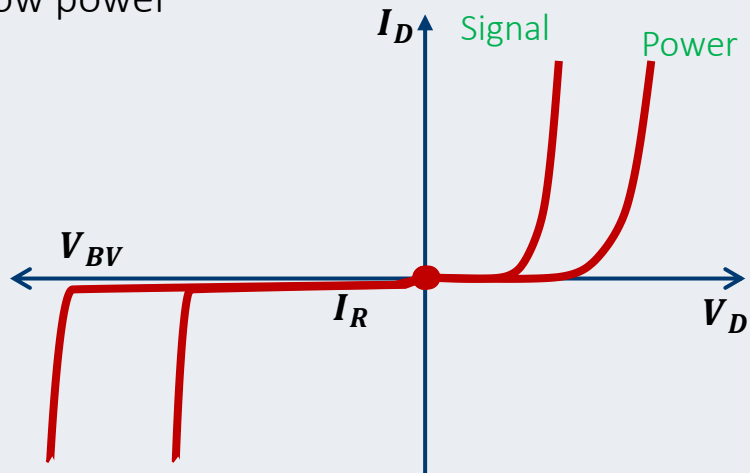

Power

n⁻ : Lightly doped
n⁺ : Heavily doped

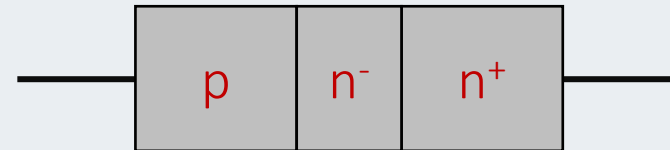

Higher currents
Higher Blocking voltages
Higher power

Higher forward voltage drop
Higher resistance in forward bias

PIN
where i stands for intrinsic

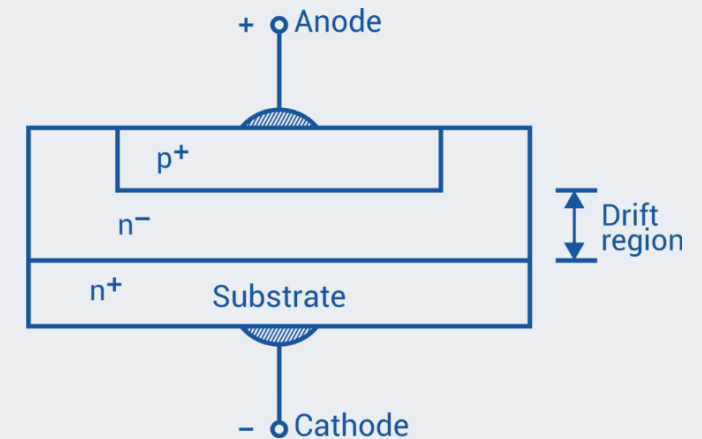

Power Diodes

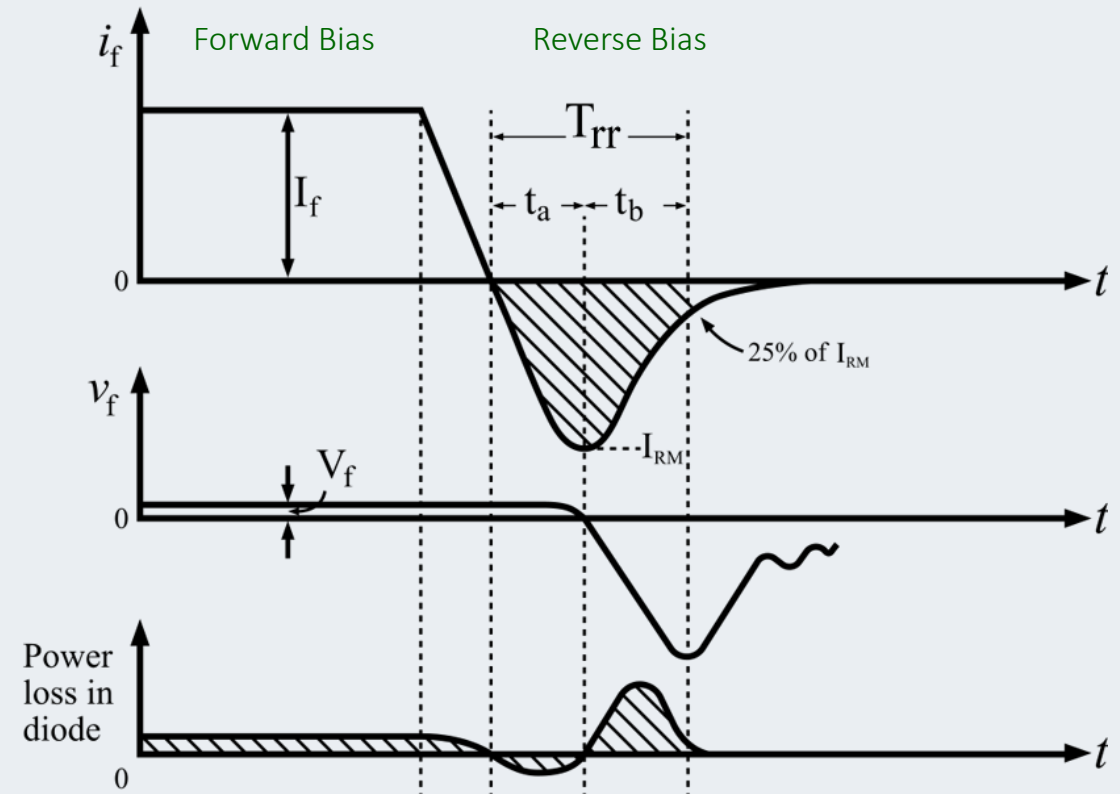
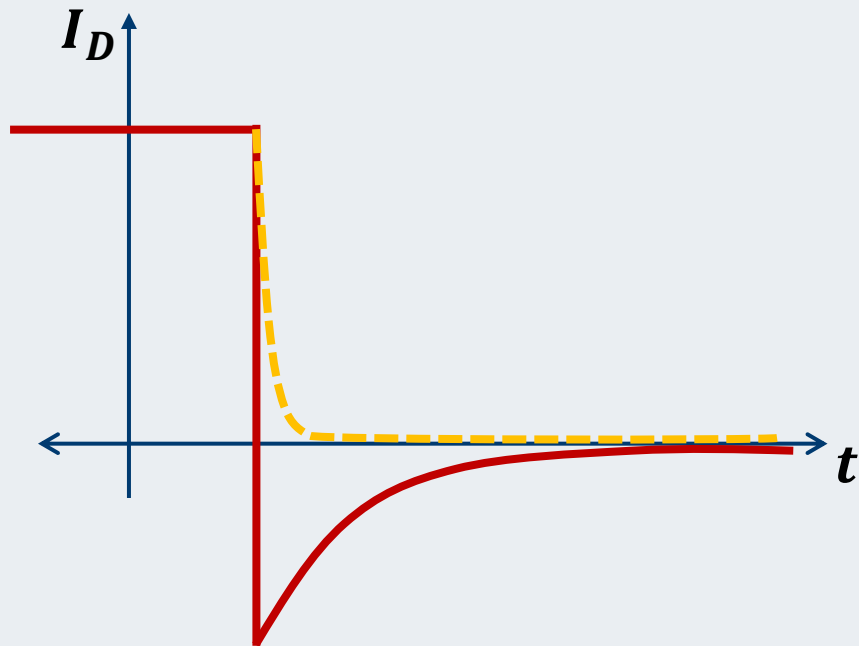
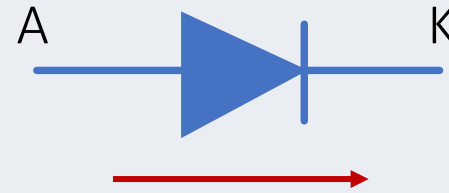
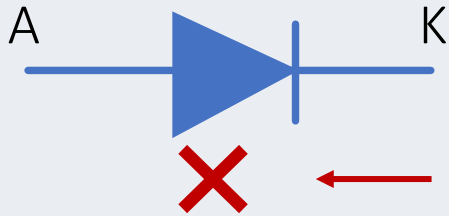

Left Figure indicates that SBDs have a lower V_F and higher I_R than the other three types.

Middle Figure indicates that t_{rr} is much shorter for SBDs and FRDs than for the other two diode types, and that if the I_R flowing during the time t_{rr} is large, losses are large.

Right Figure is the basic temperature characteristic for Si diodes. At higher temperatures, the V_F falls and the I_R increases.

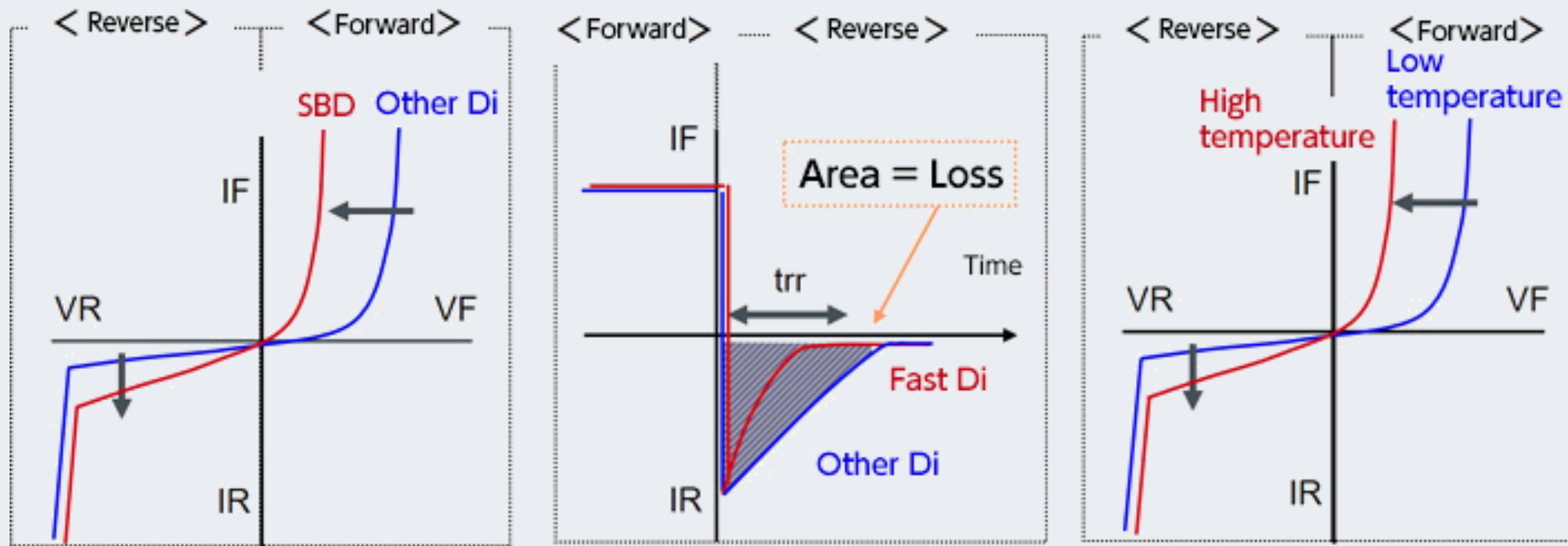

| General Purpose Diodes | Fast Recovery Diodes | Schottky Diodes |
|-------------------------------|---------------------------------|--|
| Upto 5000V & 3500A | Upto 3000V and 1000A | Upto 100V and 300A |
| Reverse recovery time – High | Reverse recovery time – Low | Reverse recovery time – Extremely low. |
| $t_{rr} \approx 25\mu s$ | $t_{rr} = 0.1\mu s$ to $5\mu s$ | $t_{rr} =$ a few nanoseconds |
| Turn off time - High | Turn off time - Low | Turn off time – Extremely low |
| Switching frequency – Low | Switching frequency – High | Switching frequency – Very high. |
| $V_F = 0.7V$ to $1.2V$ | $V_F = 0.8V$ to $1.5V$ | $V_F \approx 0.4V$ to $0.6V$ |

Wide Bandgap Semiconductors

Silicon Carbide (SiC) and Gallium Nitride (GaN)

| Properties | Si | 4H-SiC | GaN | Application |
|---|---------|-----------|-----------|---|
| Crystal structure | Diamond | Hexagonal | Hexagonal | |
| Energy gap : E_G (eV) | 1.12 | 3.26 | 3.5 | high temp. operation, emission wavelength |
| Electrical mobility : μ_n (cm ² /Vs) | 1400 | 900 | 1250 | High frequency devices |
| Hole mobility : μ_p (cm ² /Vs) | 600 | 100 | 200 | |
| Breakdown field : E_B (V/cm) x 10 ⁶ | 0.3 | 3 | 3 | Power devices |
| Thermal conductivity (W/cmK) | 1.5 | 4.9 | 1.3 | High heat dissipation |
| Saturated drift velocity : v_s (cm/s) x 10 ⁷ | 1 | 2.7 | 2.7 | High frequency devices |

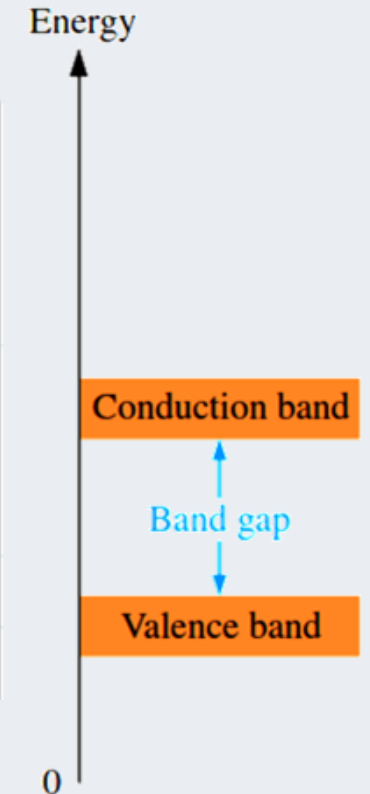

Wide Bandgap Semiconductors

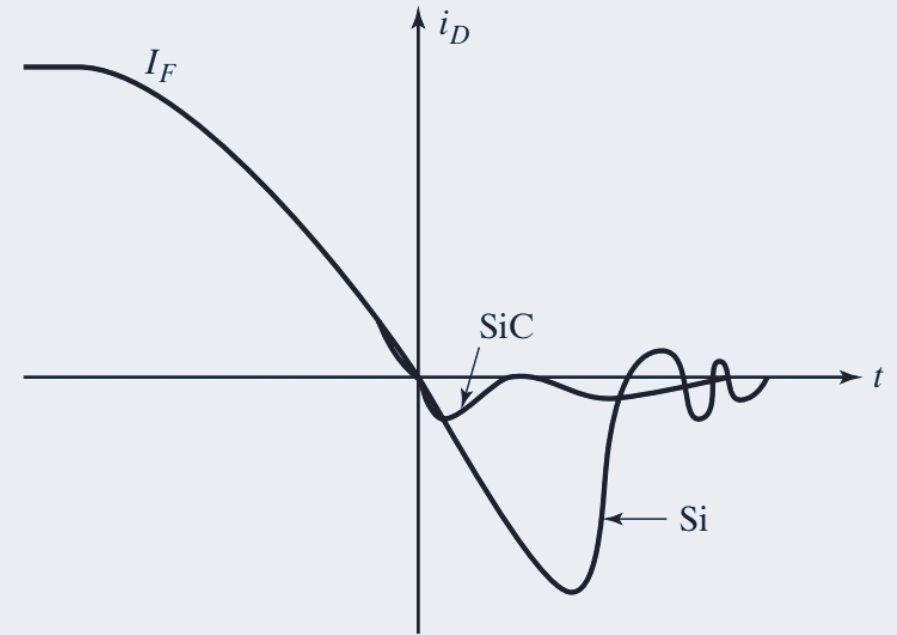
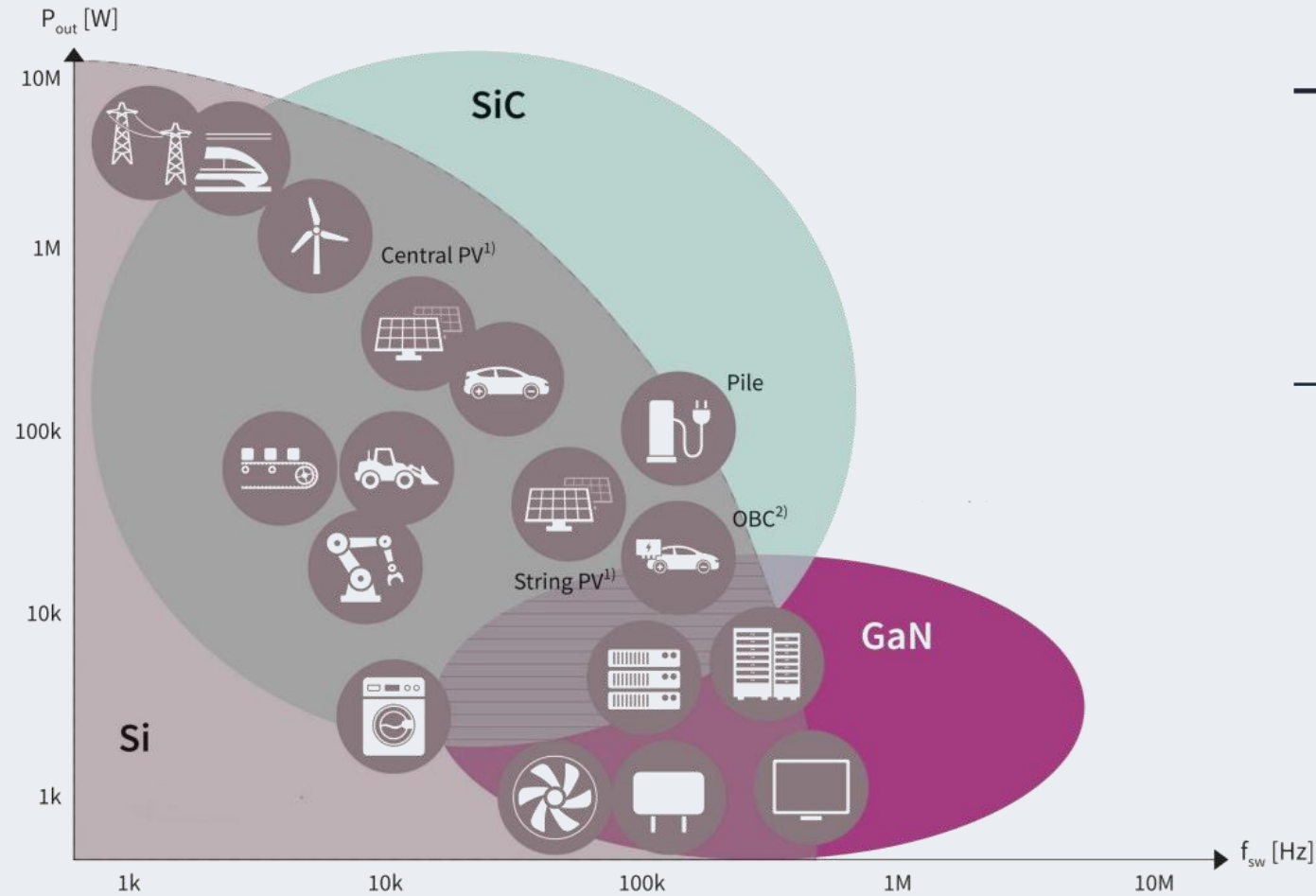

1) PV = photovoltaic inverter
2) OBC = on-board charger

Thank You!

Upcoming Courses



| Engineering College of Technology (ECT) <i>UK-Recognised Qualifications</i> | Start Date |
|--|--------------------|
| Bachelor of Engineering (Honours) in Industrial Automation | September 2026 |
| Bachelor of Engineering (Honours) in Electrical Engineering | September 2026 |
| Master of Science (Power System Analysis and Renewable Integration) | June, October 2026 |
| Master of Science (Industrial Automation and Instrumentation Control) | June, October 2026 |

Contact Us:



Website
www.ect.ac.uk



Courses

<https://www.ect.ac.uk/programmes/>



Head Office
Whittle Way, Stevenage SG1 2FS,
United Kingdom



Phone

Inside UK: 0203 582 1389

Outside UK: +44 203 582 1389