

# Microgrids and the Future of Energy Decentralisation

Dr. Walid Issa  
ECT Programme Leader

[Watch Webinar Recording Here](#)



# Electrical Grid

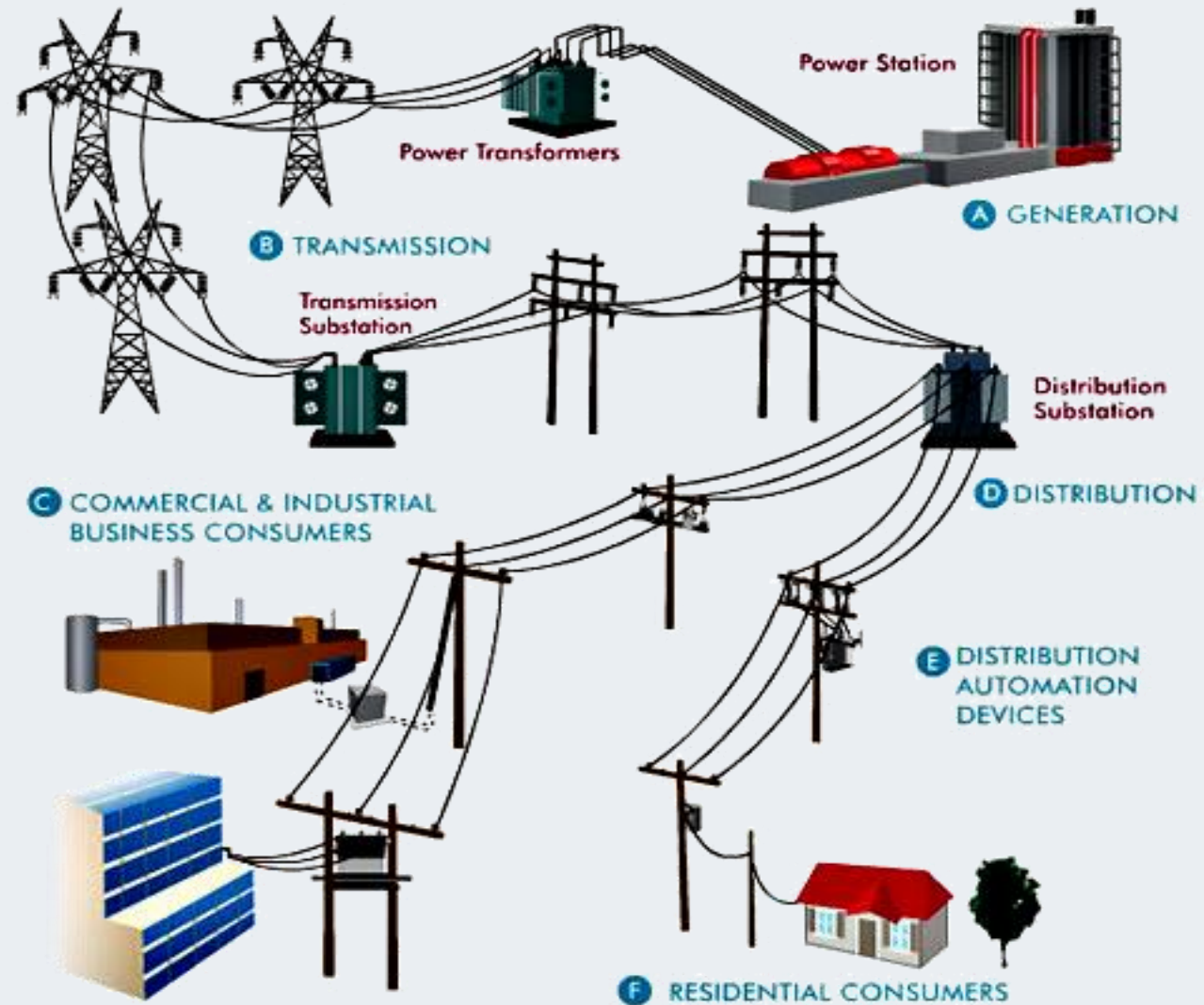

# Electrical Grid

- › Dependency on a high capacity fossil-fuel generators
- › Increasing carbon emissions
- › Getting a large amount of power in one place
- › Using a long transmission lines to deliver power
- › Not economic
- › Has low reliability against sudden faults

# Microgrid

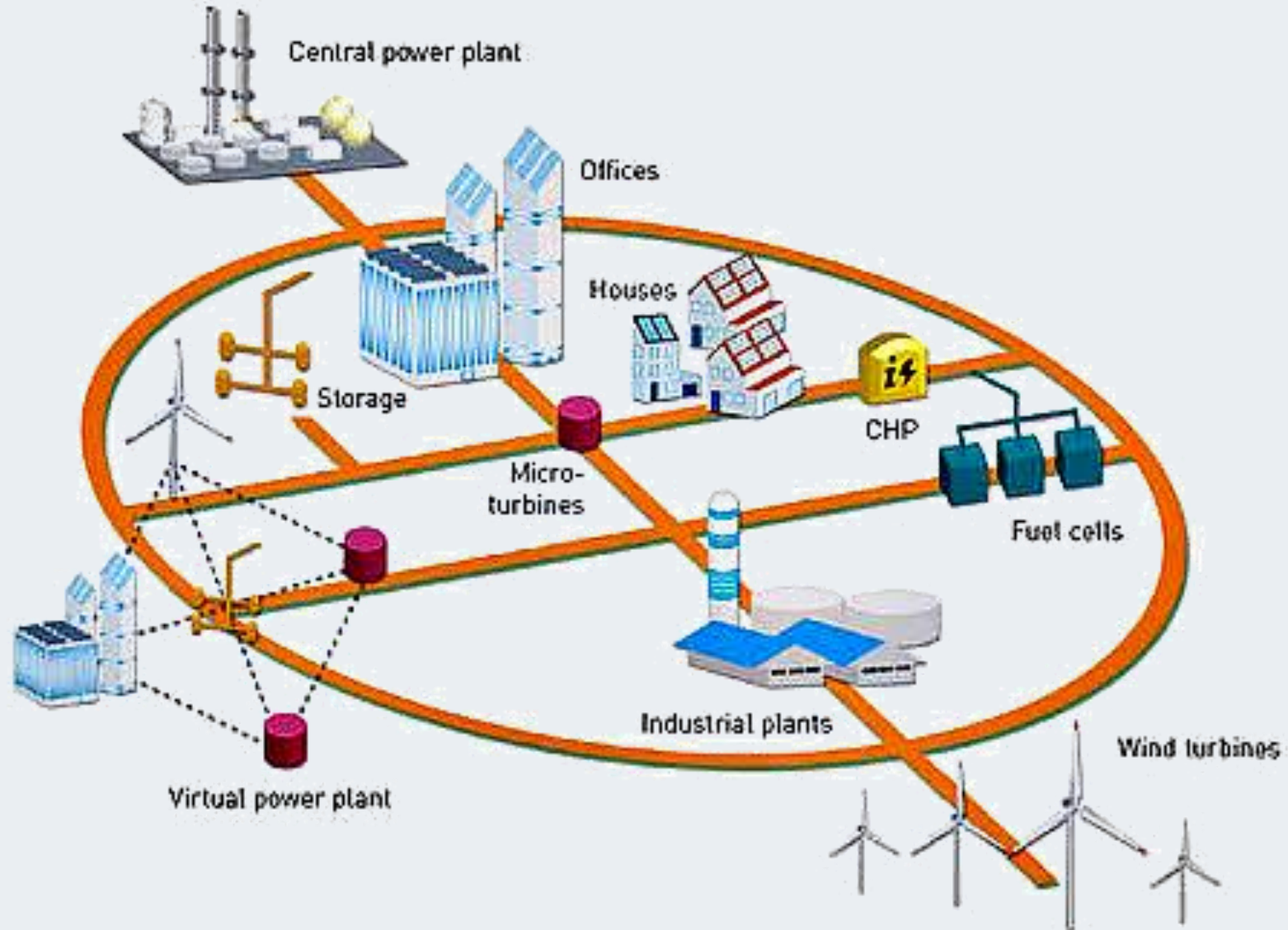

# Microgrid

- › Integrate renewable resources
- › Control the flow of power
- › Reduce Carbon emissions
- › Reduce losses
- › Reliable against sudden faults
- › Customer is a part of the grid

# GRID

# Micro-GRID

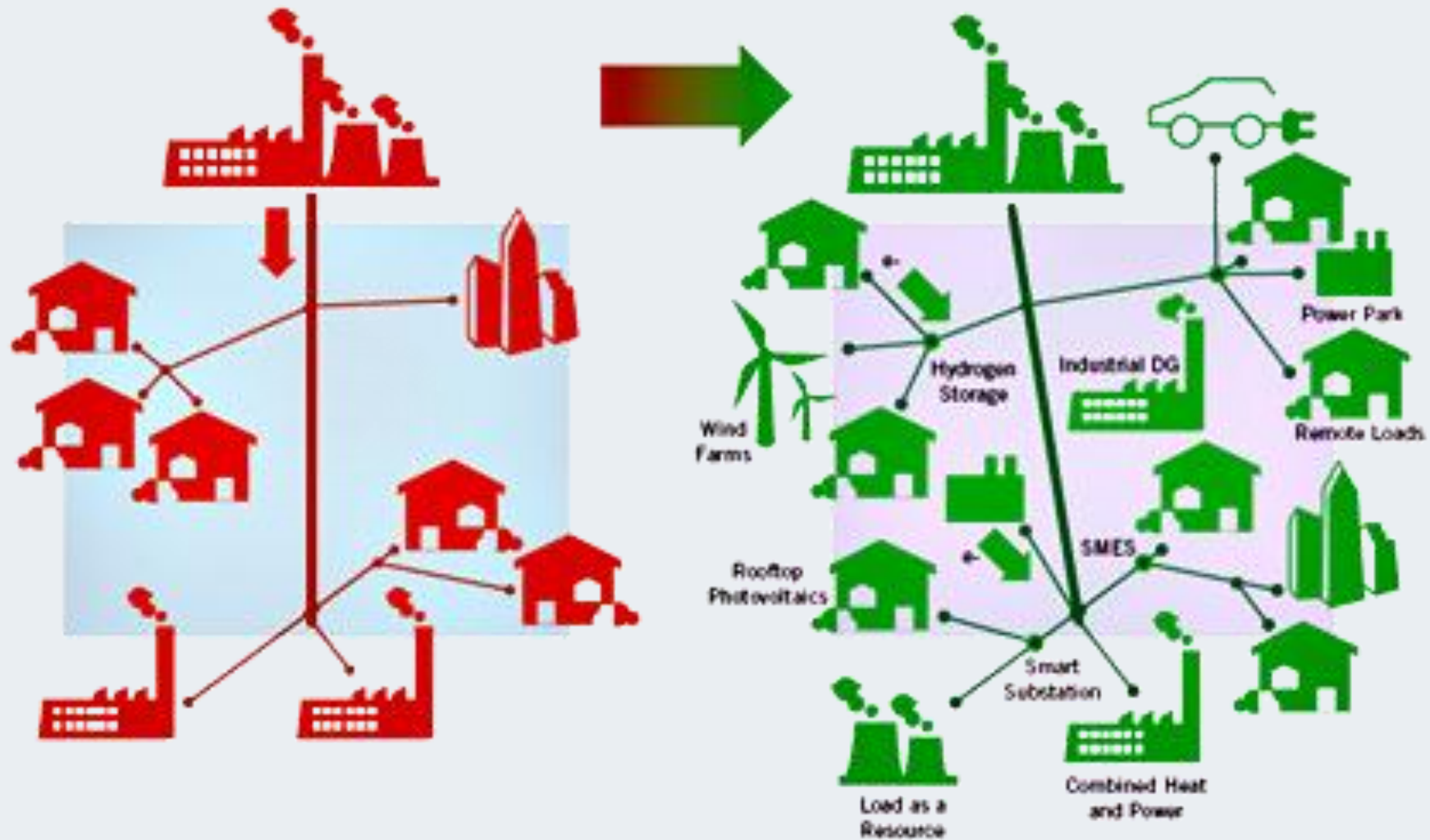

# Microgrid Modes

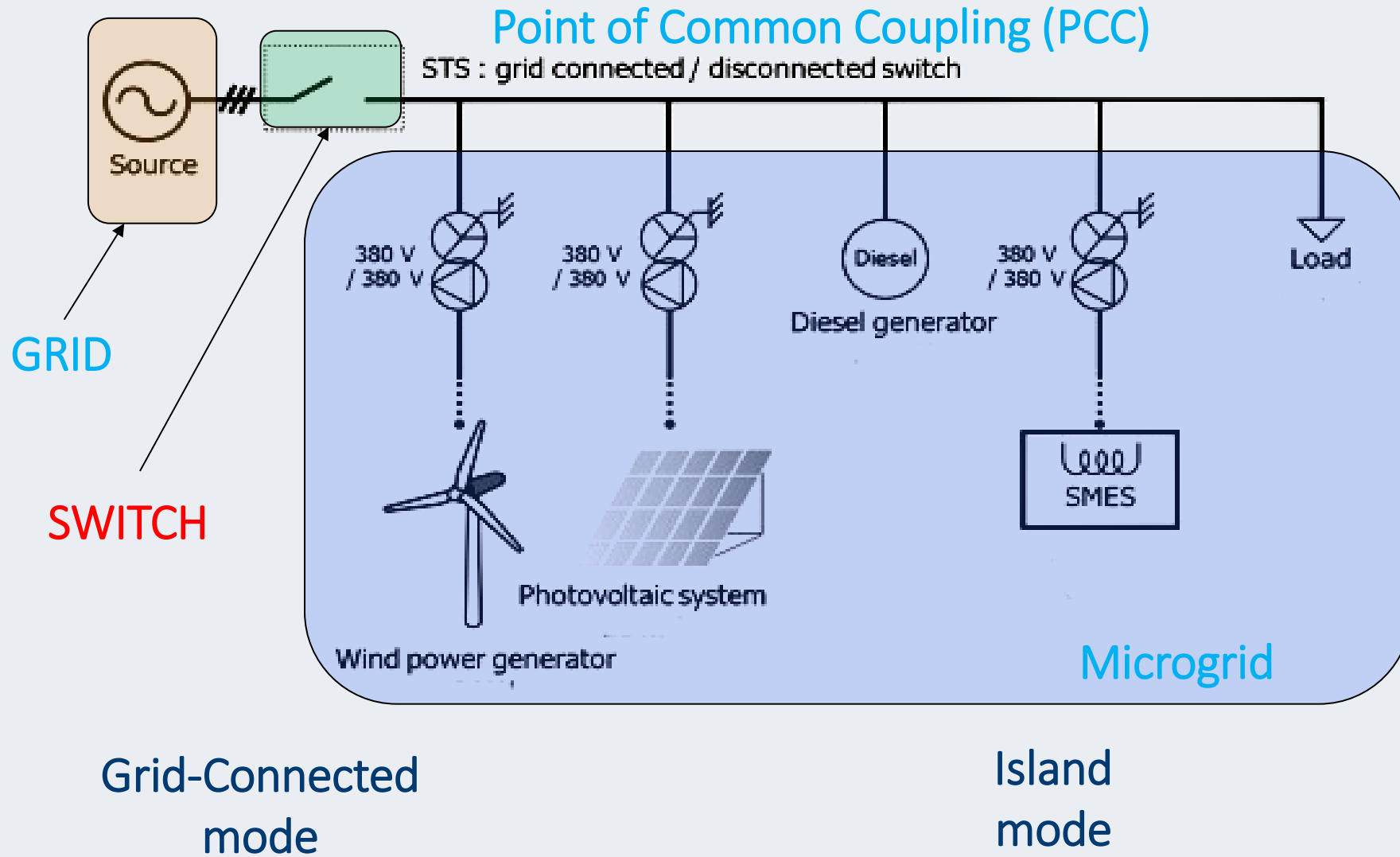

# Interfacing



Sources



Battery



DC



INVERTER

AC



Loads



Grid



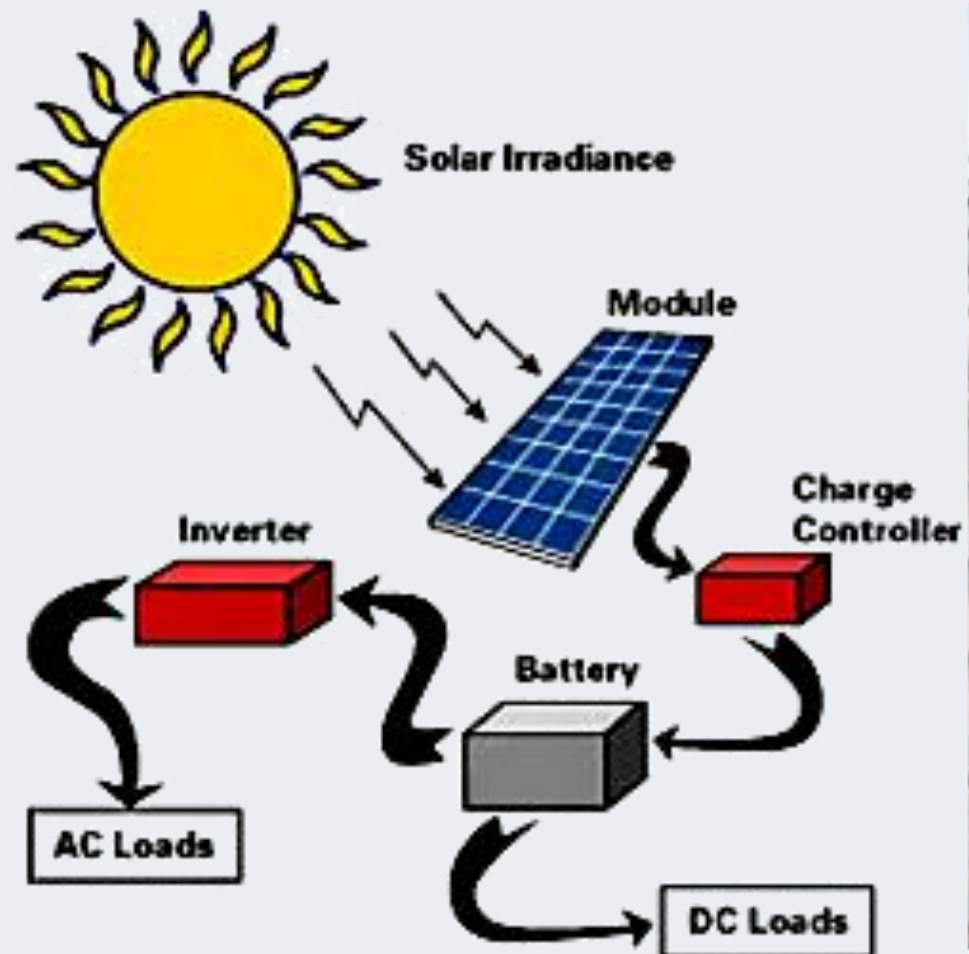

# Inverter

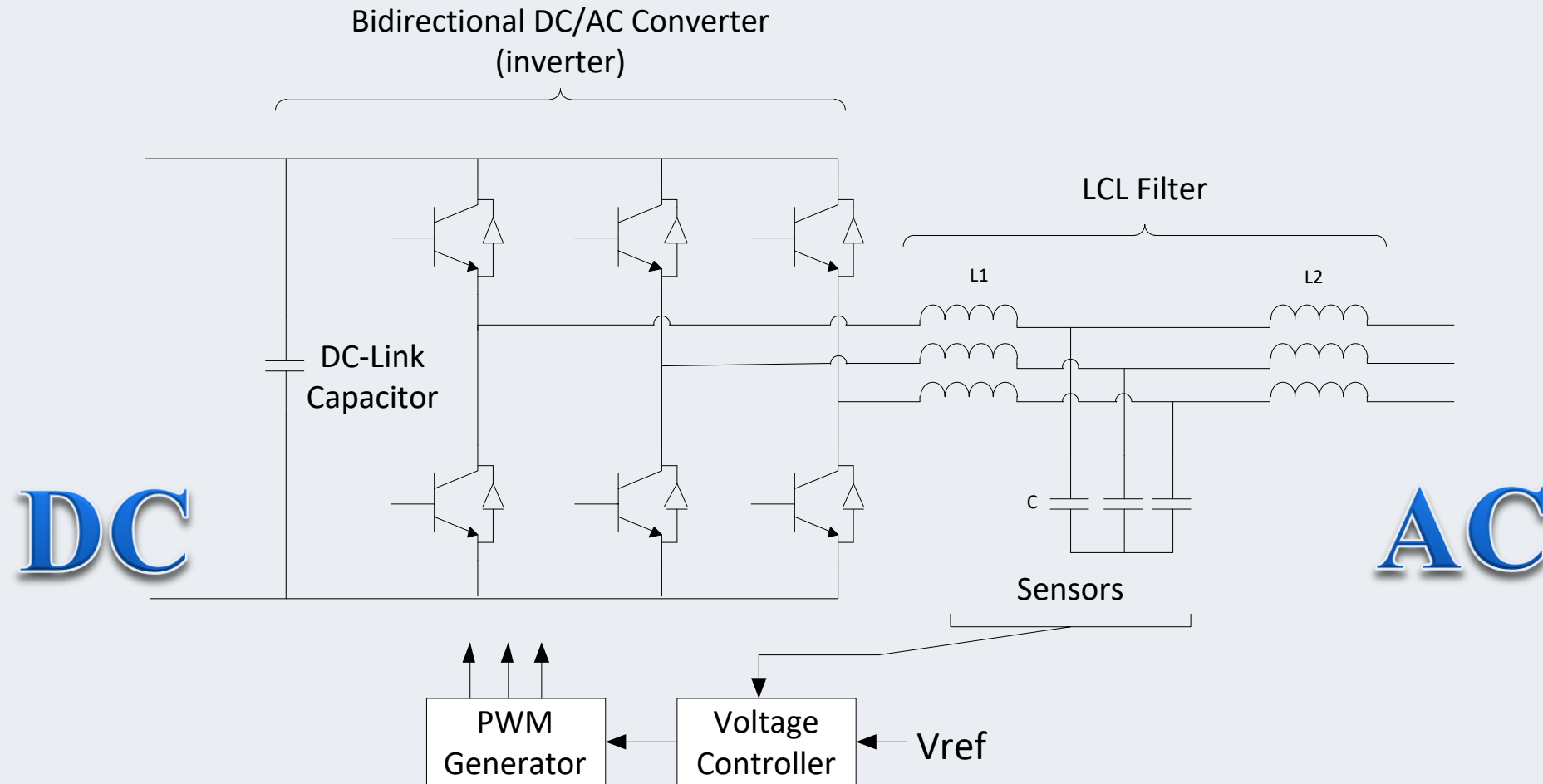

# Inverter's Topologies

Uses DC Boost to step up the DC voltage

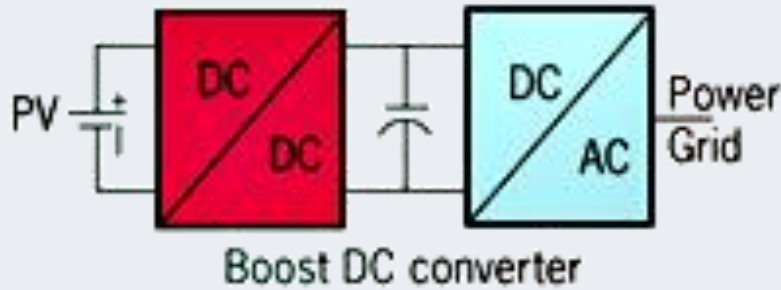

Uses transformer to step up the AC voltage

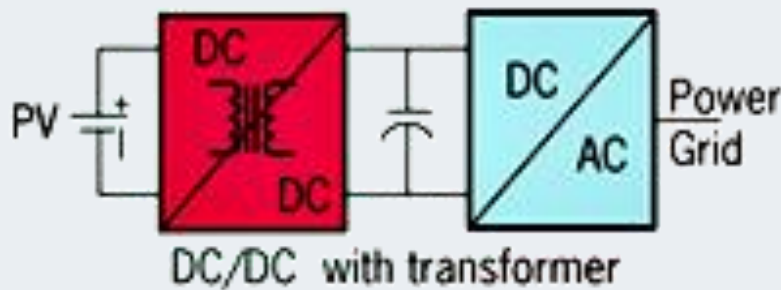
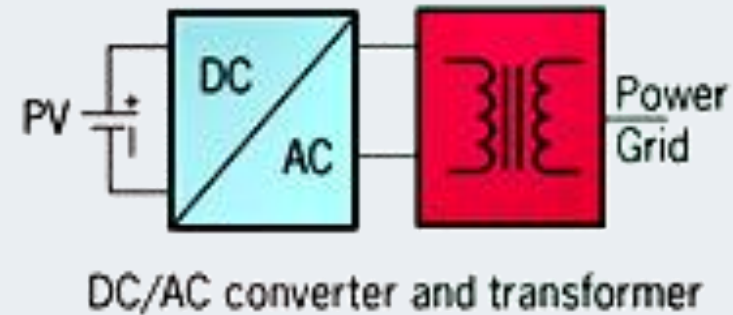

Uses transformer to step up the DC voltage

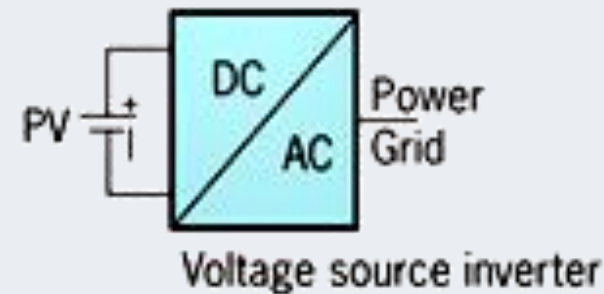

Uses many PV to step up the DC voltage

# Inverter

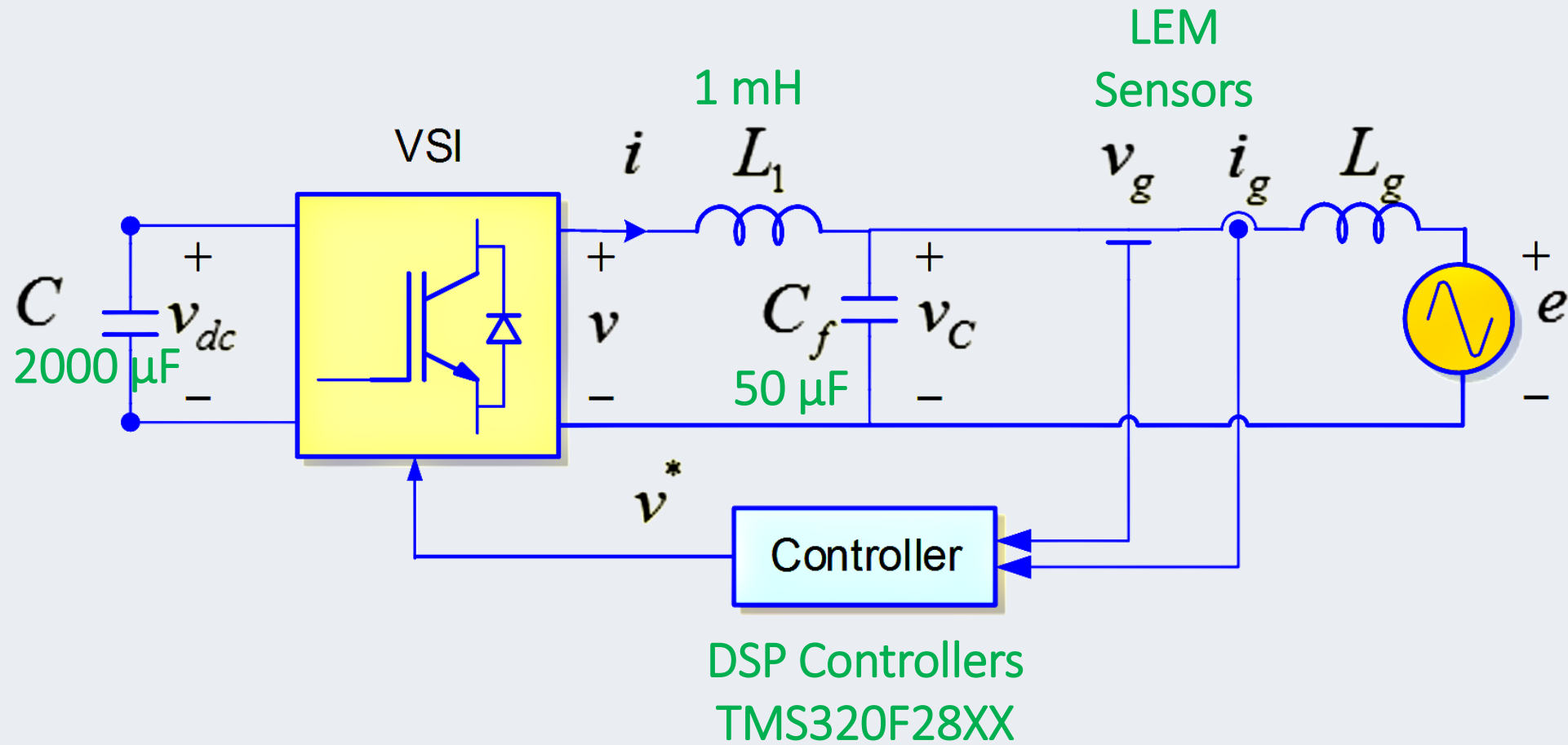

# Electric Vehicle

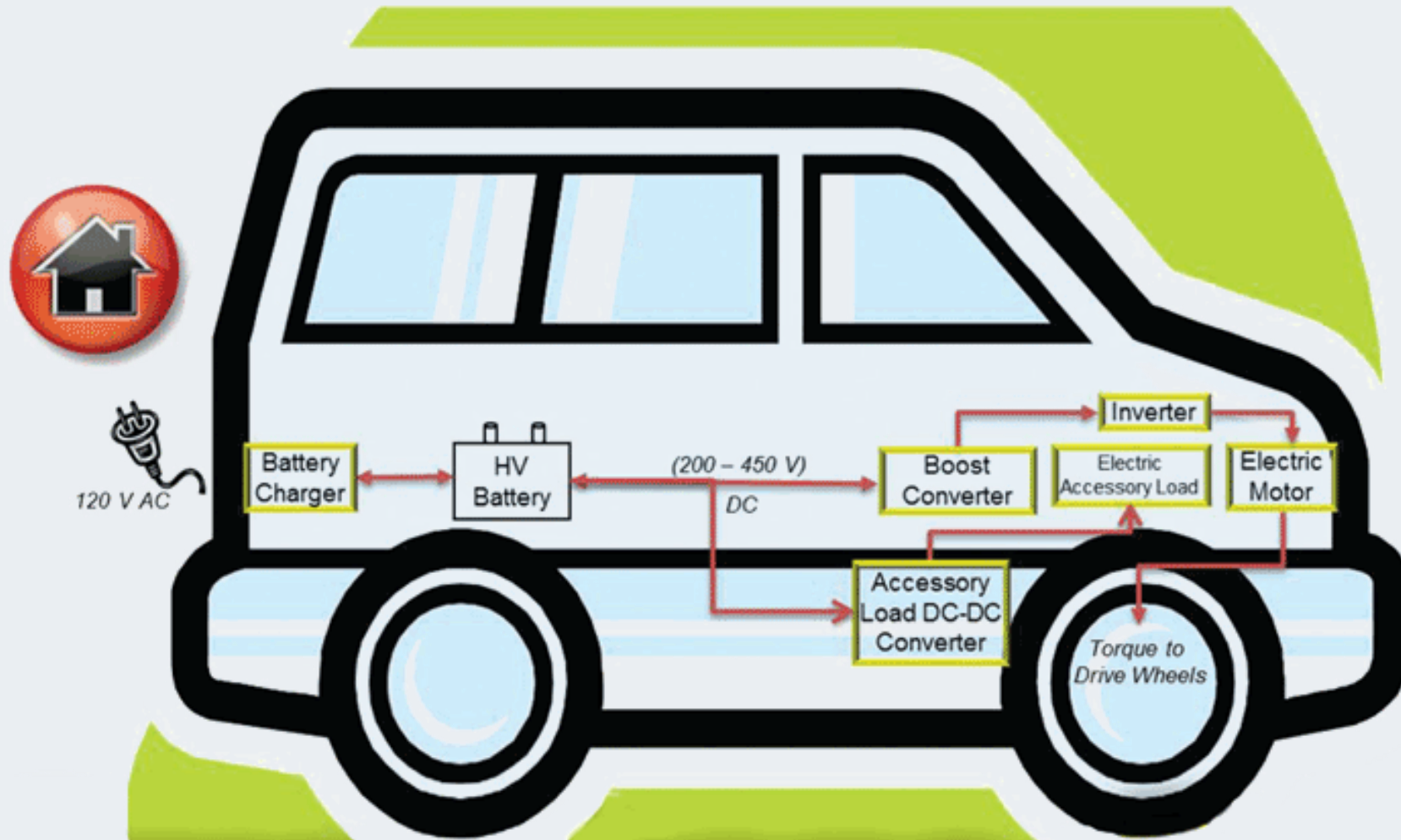

# Active & Reactive Power Measurement

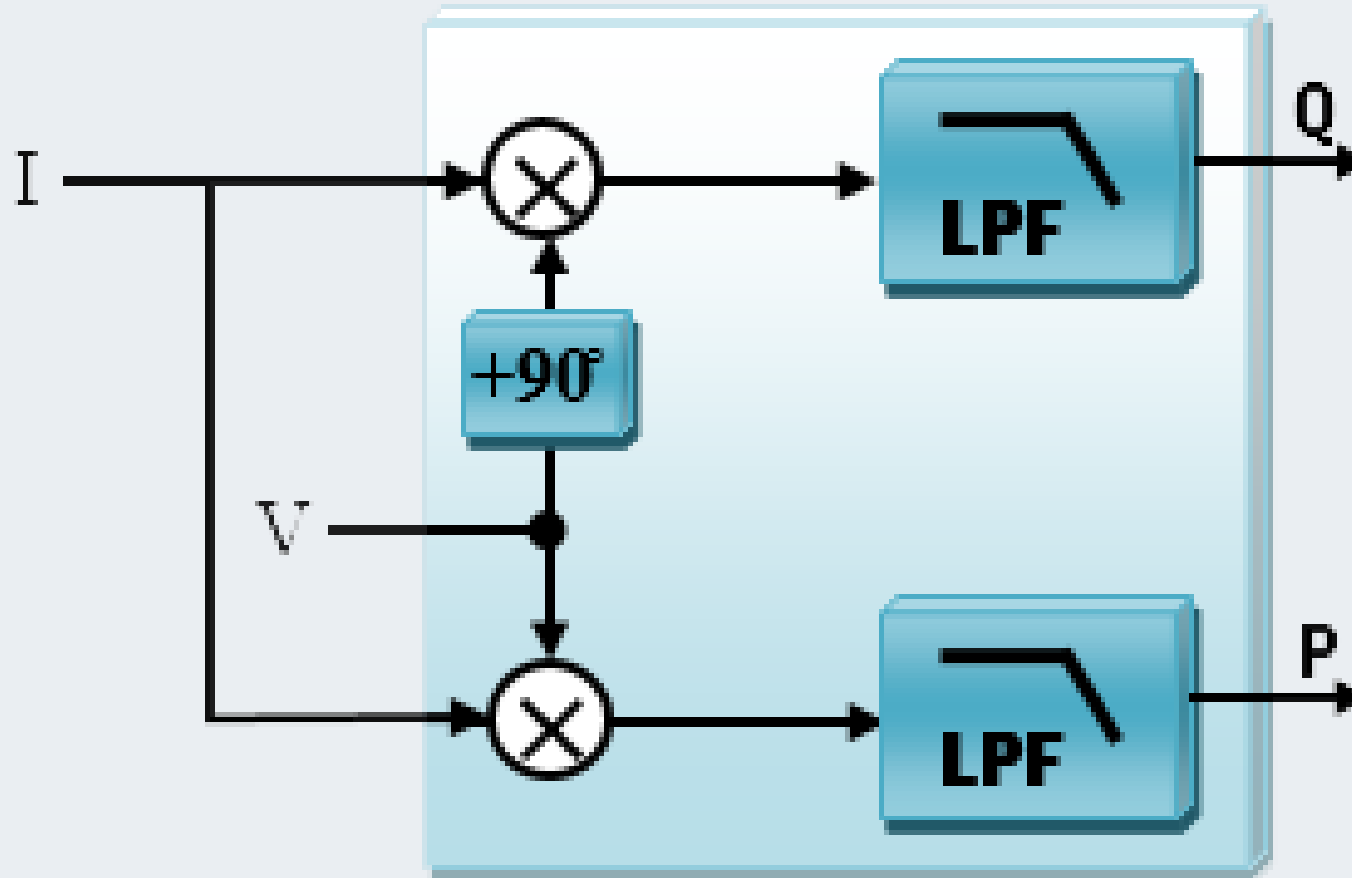

$90^\circ \rightarrow \frac{1}{4} \text{ cycle} \rightarrow \frac{1}{4} T$

# Sine wave PWM Generation

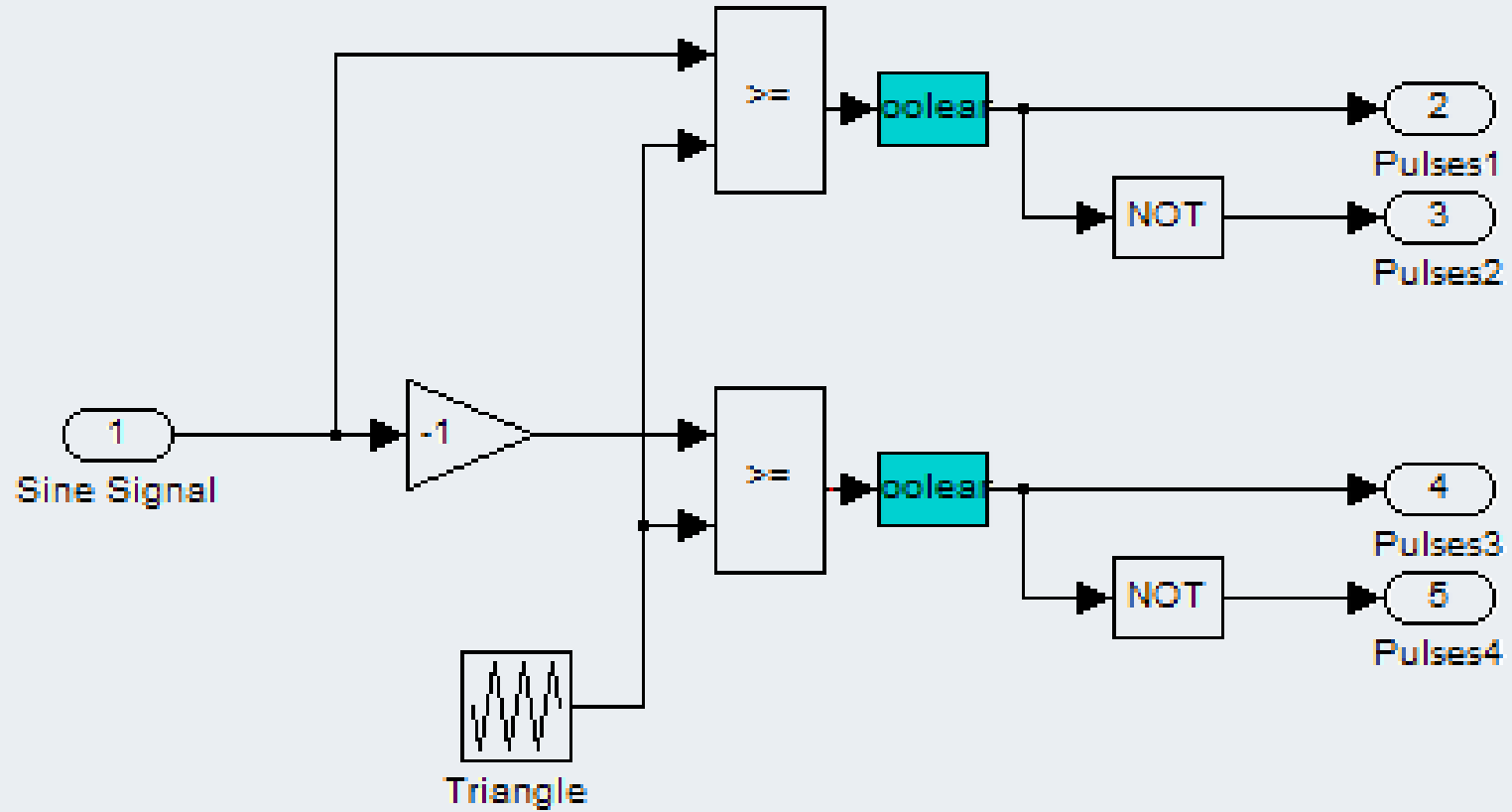

# Microgrid Literature

## 1- Voltage and Current Regulation

- **Goals:**
  - › Low Distortion
  - › No Resonance
  - › Regulated Voltage
  - › Smooth Step Response
- **Proposed Solutions:**
  - › PI, PID Controllers
  - › P+Resonant Controllers
  - › Adaptive Controllers
  - › Repetitive Controllers

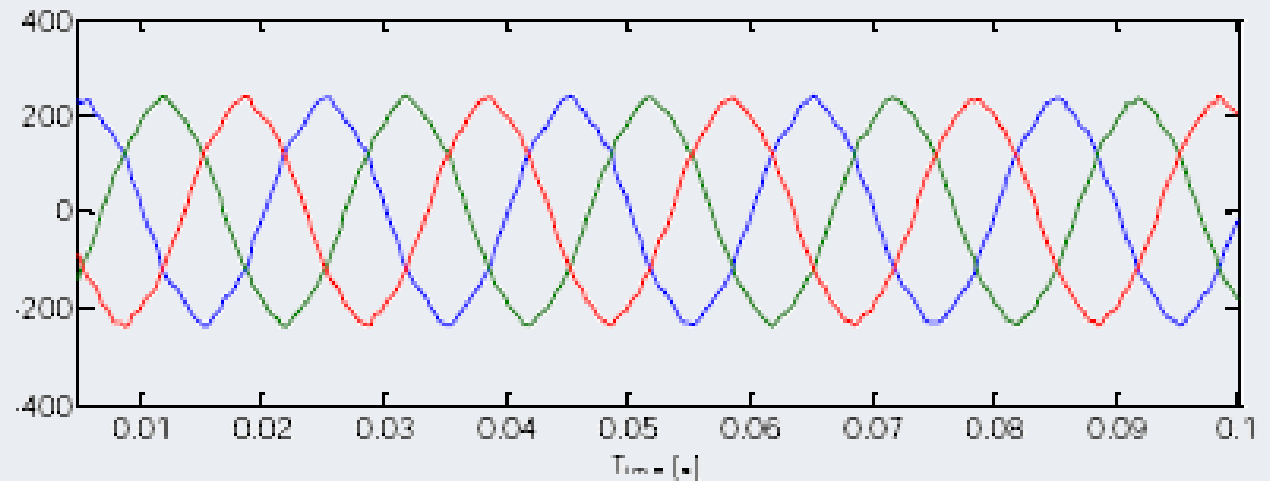

# Microgrid Literature

## 2- Power Sharing

- **Goals:**
  - › Adequate Power sharing
  - › Accurate Power control
  - › Without Communication if possible
  - › Smooth Step Response
- **Proposed Solutions:**
  - › Master – Slave Controllers
  - › Current Chain Scheme
  - › Droop Control

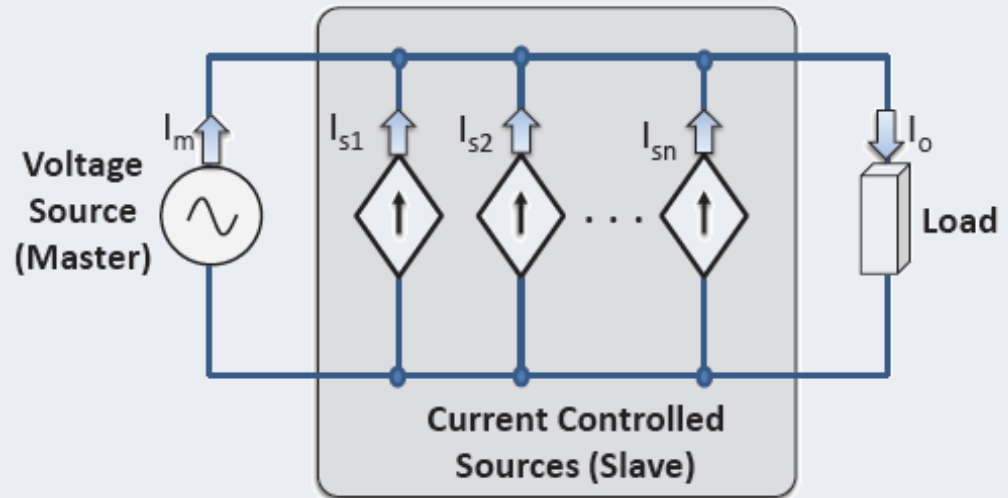

# Microgrid Literature

## 3- Power Sharing' ('Droop Control')

- Goals:
  - › Accurate Reactive Power control
  - › Small Frequency and voltage deviations
  - › Harmonics Sharing
  - › Smooth Step Response
- Proposed Solutions:
  - › PID Control
  - › Angle droop controller
  - › External supplementary loops

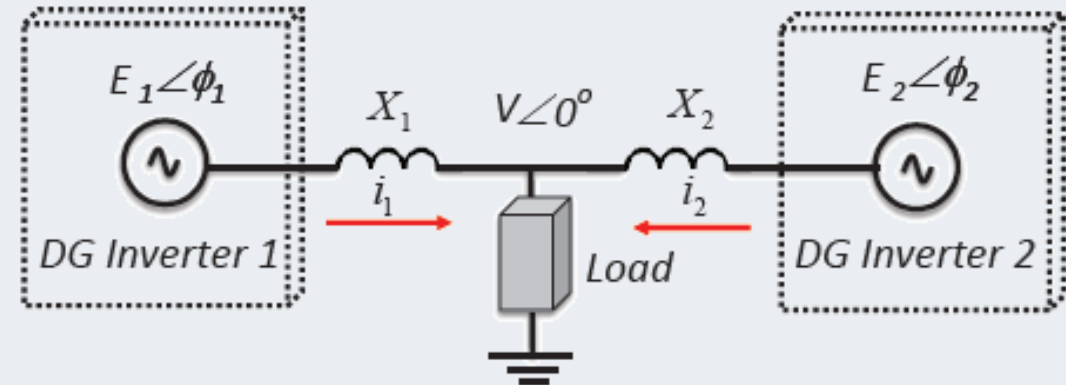

# Microgrid Literature

## 4- Islanding Detection

- **Goals:**
  - › Detect the grid absence within 2 sec
- **Proposed Solutions:**
  - › Passive Methods
    - › Voltage, Frequency, phase deviations
  - › Active Methods
    - › Positive Feedback, harmonic injection, ...

# Microgrid Literature

- 5- Power Management and Central Control
  - Goals:
    - › A manager should decide the power for each inverter
    - › Mode Controlling
  - Proposed Solutions:
    - › Hierarchical Control
      - › Primary Control
      - › Secondary Control
      - › Tertiary Control

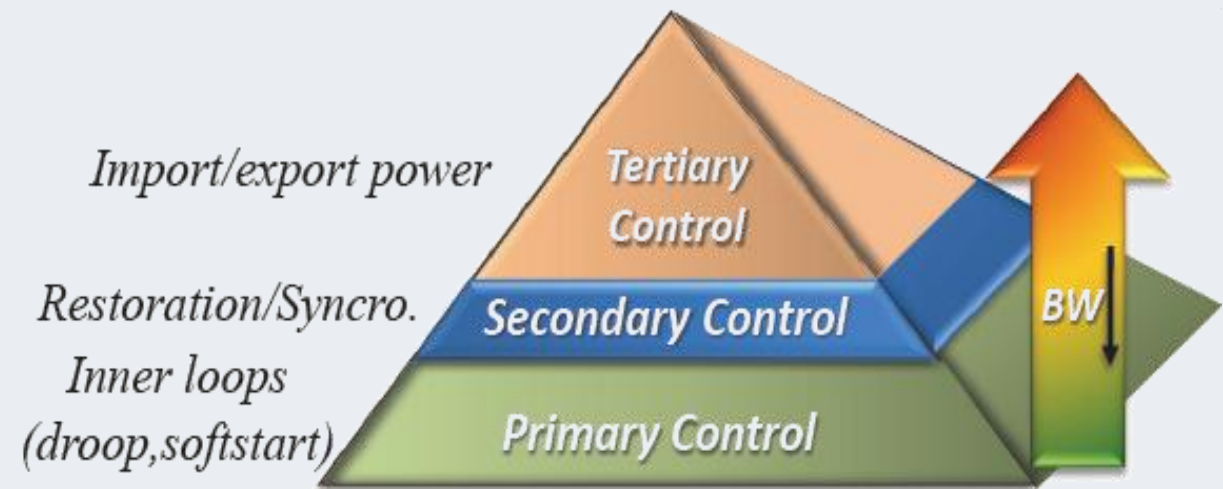

# Research Goals

## Paralleling Inverters operation in Island Mode

- ✓ Circulation currents
- ✓ Power sharing in island mode
- ✓ Smooth Transition
- ✓ Microgrid stability

# Parallel Inverters

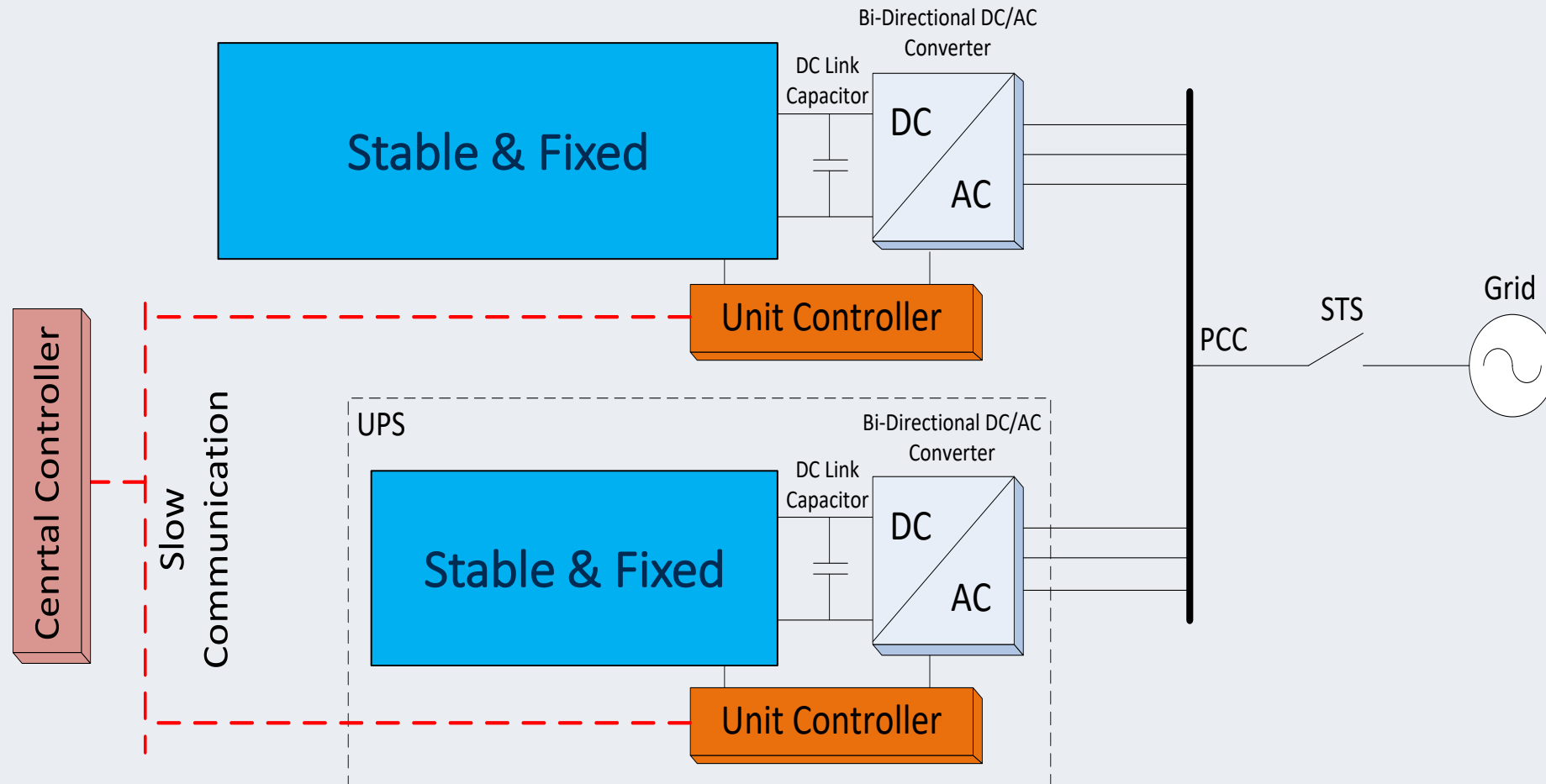

# Methodology

- › Microgrid Modeling
- › Proposing a controller
- › MATLAB/SIMULINK
- › Practical implementation

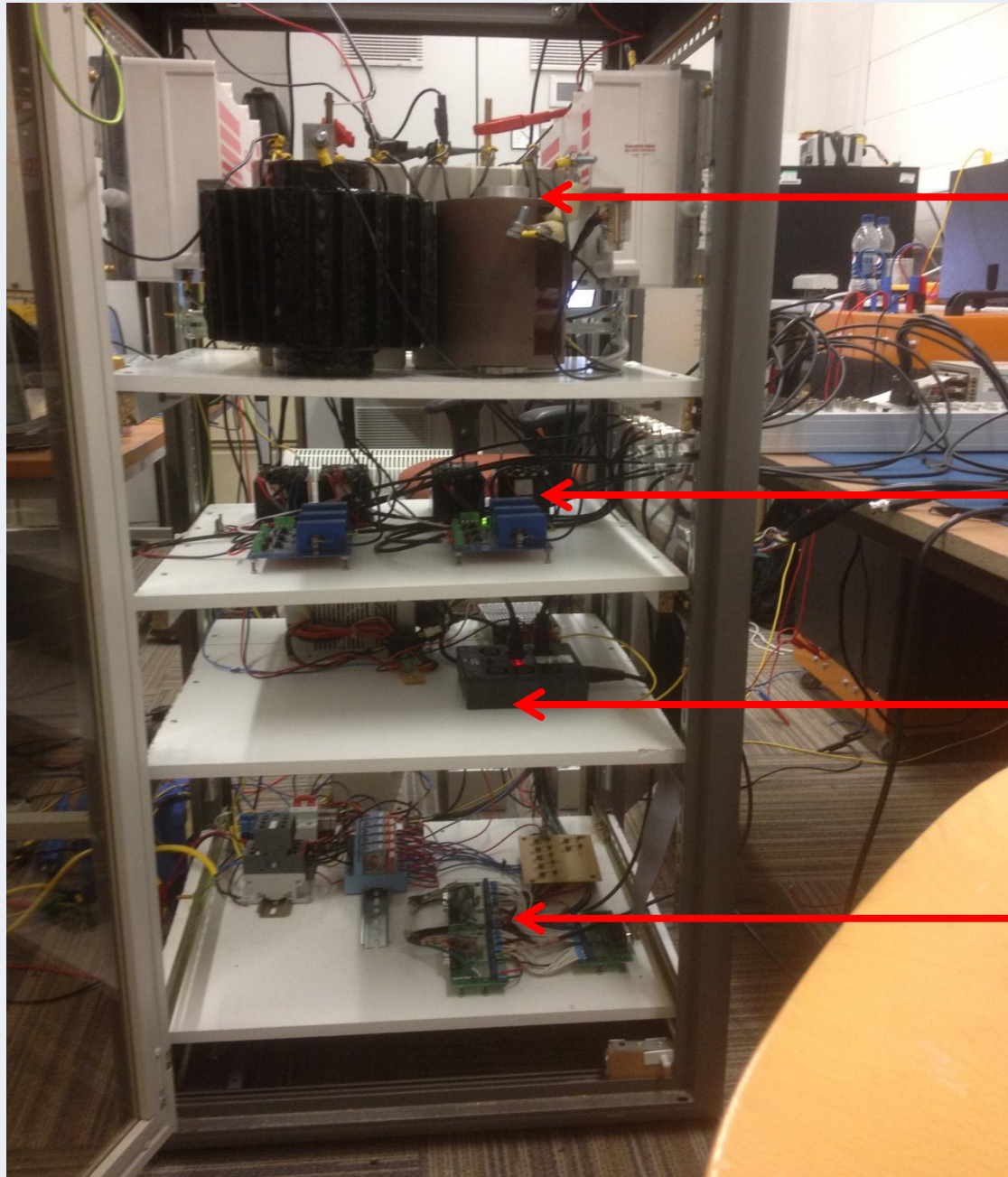

IGBTs and  
Filters

Voltage and  
current  
sensors

Power supply

Interfacing  
and switching  
boards

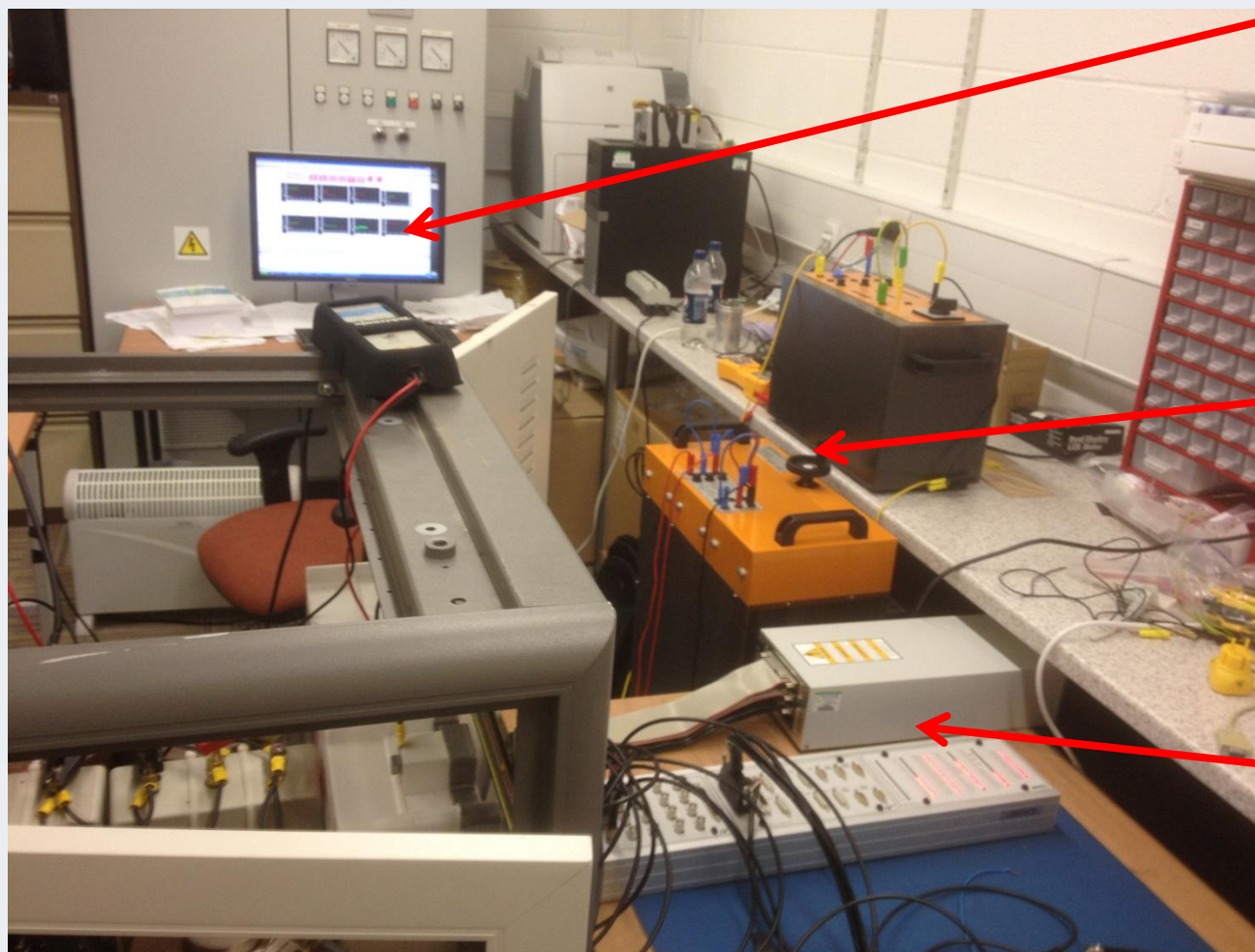

Interfacing and  
monitoring platform

Loads

dSpace Control unit

# Interfacing Platform



# Results

## Reactive Power sharing

Output Voltage of both inverters

THD = 1.8%

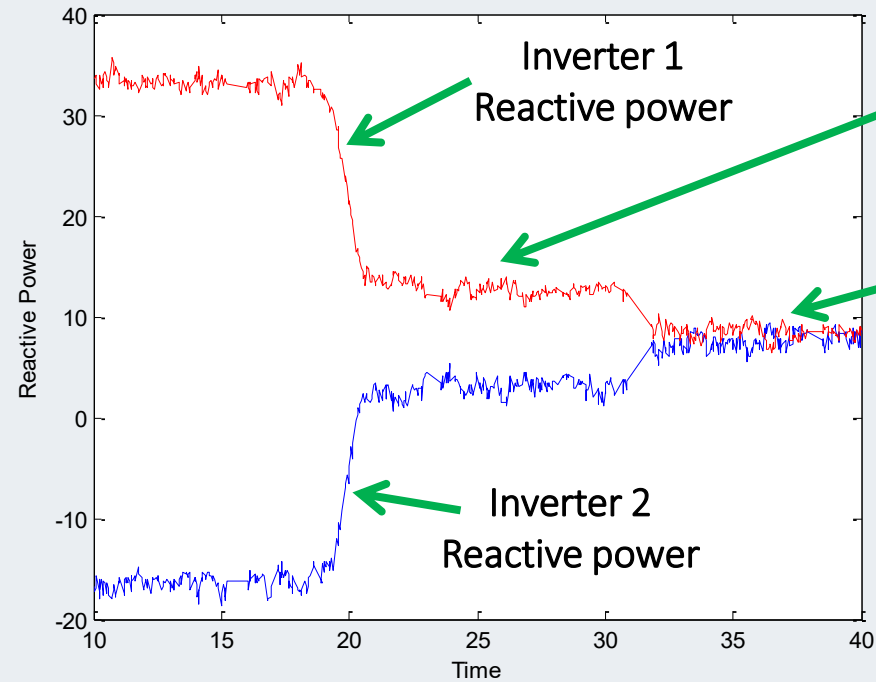
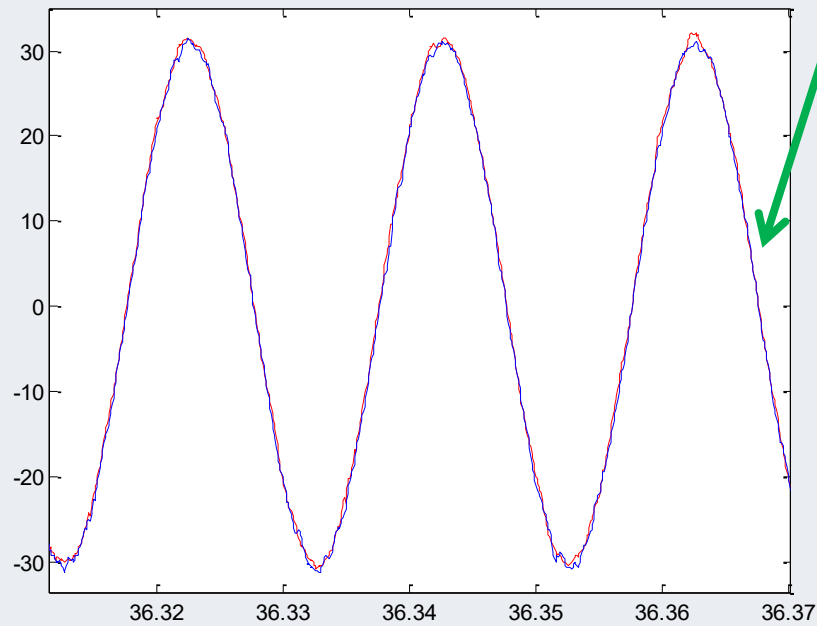

First controller

Second controller

# Keywords

- › Droop control
- › Voltage & Current controllers
- › Reactive power sharing in island mode
- › Islanding Detection
- › Supervisory Control
- › MPPT for solar inverters

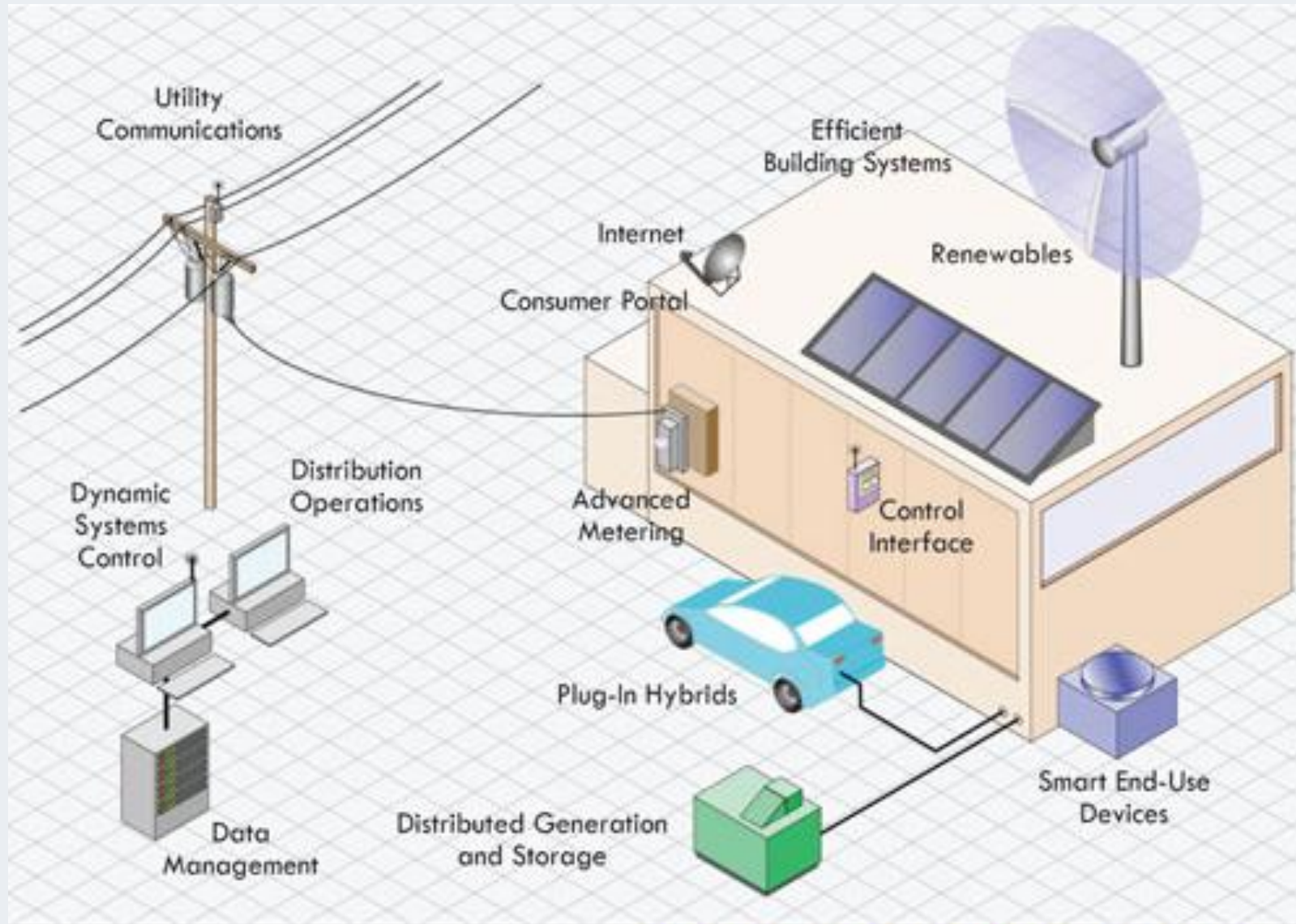

### **CAPABILITIES OF A SMART MICROGRID**

This revolutionary system design meets U.S. energy challenges and maximizes consumer and business value.

# Thank You!

# Upcoming Courses

<b>Engineering College of Technology (ECT)</b> <i>UK-Recognised Qualifications</i>	<b>Start Date</b>
Bachelor of Engineering (Honours) in Industrial Automation	September 2026, February 2027
Bachelor of Engineering (Honours) in Electrical Engineering	September 2026, February 2027
Master of Science (Power System Analysis and Renewable Integration)	October 2026, February 2027
Master of Science (Industrial Automation and Instrumentation Control)	October 2026, February 2027

# Contact Us:

---



## Website

[www.ect.ac.uk](http://www.ect.ac.uk)



## Courses

<https://www.ect.ac.uk/programmes/>



## Head Office

Whittle Way, Stevenage SG1  
2FS, United Kingdom



## Phone

Inside UK: 0203 582 1389

Outside UK: +44 203 582 1389