



Mysteries: Why the UPS Failed During a Blackout - But Passed All Tests?

21 May 2026

[Watch Webinar Recording Here](#)

Emeritus Professor Akhtar Kalam

EIT EMERITUS PROFESSOR



About EIT

We are dedicated to ensuring that you receive a world-class education and gain skills that you can immediately implement in the workforce.



Engineering Specialists

EIT is one of the only institutes in the world specializing in Engineering. We deliver professional certificates, diplomas, advanced diplomas, undergraduate and graduate certificates, graduate diplomas, bachelor's and master's degrees, and a Doctorate of Engineering.



Industry Oriented Programs

Our programs are designed by industry experts, ensuring you graduate with cutting-edge skills that are valued by employers. Our program content remains current with rapidly changing technology and industry developments.



World-Class Australia Accredited Education

Our vocational programs and higher education degrees are registered and accredited by the Australian Government. We have programs that are also recognized under three international engineering accords.



Industry Experienced Lecturers

Our lecturers are highly experienced engineers and subject specialists with applied knowledge. The technologies employed by EIT, both online and on-campus, enable us to source our lecturers from a large, global pool of expertise.



Unique Delivery Model

We deliver our programs via a unique delivery methodology that makes use of live and interactive webinars, an international pool of expert lecturers, dedicated learning support officers, and state-of-the-art such as hands-on workshops, remote laboratories, and simulation software.



ECT delivers interactive and online **UK qualifications**. ECT is committed to providing students with a world-class education, where they acquire the knowledge and skills that are applicable and valued in industry.

- Bachelor of Engineering (Honours) in Industrial Automation
- Bachelor of Engineering (Honours) in Electrical Engineering
- Master of Science (Power System Analysis and Renewable Integration)
- Master of Science (Industrial Automation and Instrumentation Control)

Learn more [here](#).

Registered UK Higher Education Provider | UKPRN: 10089771



ECST delivers a **South African accredited qualification** on-campus. ECST is committed to providing students with a world-class education, where they acquire the knowledge and skills that are applicable and valued in industry.

- Bachelor of Engineering Technology in Electrical Engineering (SAQA 123645)

Learn more [here](#).

The Engineering College of Science and Technology (Pty) Ltd is provisionally registered with the Department of Higher Education and Training until 31/12/2028 as a private higher education institution under the Higher Education Act, 1997. Registration certificate no. 2025/HE07/007.

Disclaimer



The courses and qualifications mentioned in this presentation are offered by separate legal entities operating in different jurisdictions – one in Australia, one in South Africa and one in the United Kingdom. Each entity is subject to its own local regulatory requirements and accreditation standards.

Prospective students should refer to the relevant institution's official website for accurate, up-to-date information specific to their location, including course availability, fees, regulatory status, and enrolment conditions.

- For the Engineering Institute of Technology (EIT) visit: <https://www.eit.edu.au/>
- For the Engineering College of Technology (ECT) visit: <https://www.ect.ac.uk/>
- For the Engineering College of Science and Technology (ECST) visit: <https://www.ecst.ac.za/>

Event Conduct



Please keep discussion lawful and respectful; follow the moderator's directions.
Do not share illegal or abusive content. Recording is not permitted unless authorised.
Breaches may lead to removal.

Introduction – Presenter



Emeritus Professor Akhtar Kalam

Emeritus Professor at Victoria University and EIT.

Academic Director and Chair of the Academic Board - Texila College Australia.

Director of Al-Kalam Educational Solutions.

Editor-in-Chief of AJEEE

Distinguished Professor/Adjunct Faculty in Australia, India, Malaysia and Oman.

He has published over 610 publications in his area of expertise and has written over 29 books.

Supervised 51 postgraduate research students to graduation, including 39 PhD's and 12 MEngs. Currently, 10 postgraduate research students (four PhD students at VU and six DEng students at EIT) are being supervised.

Public, University, and Motivational Lecturer.

Consultant for the electricity supply industries in Australia and overseas.

Assisted in change management plans for Universities and the higher education sector.

Education

The University of Bath, Bath, UK, D.Eng., Electrical Engineering

The University of Oklahoma, Norman, USA, MS, Electrical Engineering

Aligarh Muslim University, Aligarh, India, BSc. Eng., Electrical Engineering

St Xavier's College, Calcutta, India, Applied Science

Professional Society Activities

Australian Institute of Energy – Fellow

Engineers Australia – Fellow

The Institution of Engineers and Technology, UK – Fellow.

The Institution of Electrical and Electronic Engineers, USA –Life Senior Member.



“My vision is to provide exciting higher education science and engineering courses, research, consultancy and collaborate in development work of the industry and communities within Australia and beyond.”

Agenda



	The Mystery
	Learning Objectives
	Background Information
	Hidden Failures
	Checklist
	Case Study
	Discussion and Q&A



The Mystery

The Incident

The Report:

“When the blackout occurred, the UPS failed within seconds.”

Yet:

- Monthly tests were successful.
- Battery inspections showed normal values.
- No alarms were active.
- Maintenance logs were excellent.
- Vendor confirmed healthy operation.

Question:

Why did the UPS fail only during the real event?



Learning Objectives

By the end of this session, you should be able to:

- Understand UPS operating principles.
- Identify hidden UPS failure modes.
- Analyse battery-related failures.
- Recognise inverter and transfer problems.
- Understand maintenance blind spots.
- Evaluate real-world testing limitations
- Recommend design improvements?

7 Scientifically Proven Ways to Maximize Learning Outcomes



- ✓ Assess students' learning
- ✓ The reversed learning model
- ✓ Learning using multimedia
- ✓ Collaborative learning
- ✓ Interactive learning
- ✓ Use of practical tools and teaching aids
- ✓ Brainstorming sessions for students

What is a UPS?

Uninterruptible Power Supply (UPS)

Purpose:

Provides continuous power during:

- Utility failure
- Voltage sag
- Frequency disturbance
- Switching transients
- Generator startup delays

Common Applications:

Hospitals
Data centres
Airports
Telecommunication systems
Industrial control systems
Financial institutions

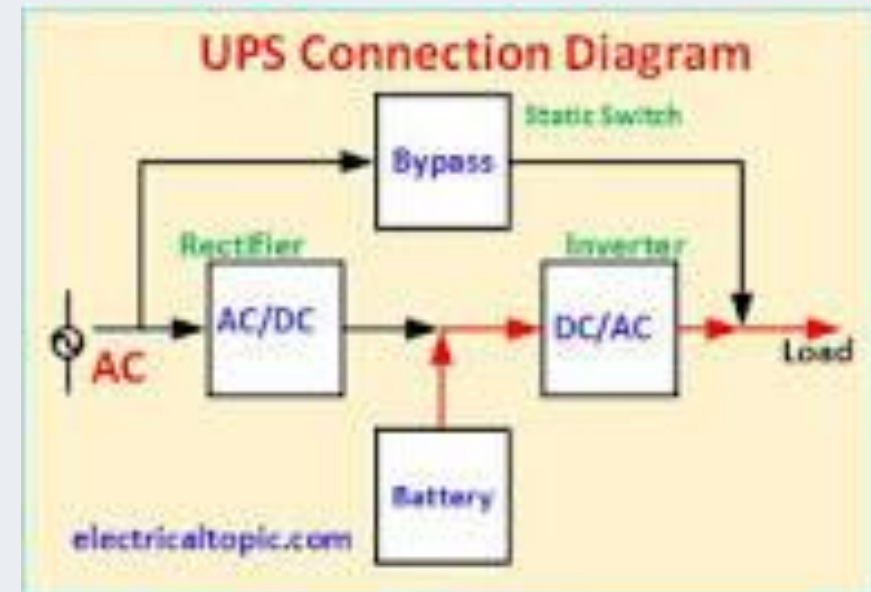

Various types of UPS

Standby (Offline) UPS

The most basic and cost-effective type, ideal for home devices like PCs and routers.

- **How it works:** Under normal conditions, utility power passes directly through the UPS to the connected equipment.
- **During a power failure:** When the power fails or the voltage drops, it switches to its internal battery via an inverter.
- **Pros/Cons:** It is compact and efficient but has a brief "transfer time" (typically 2–10 ms), which might disrupt highly sensitive electronics.

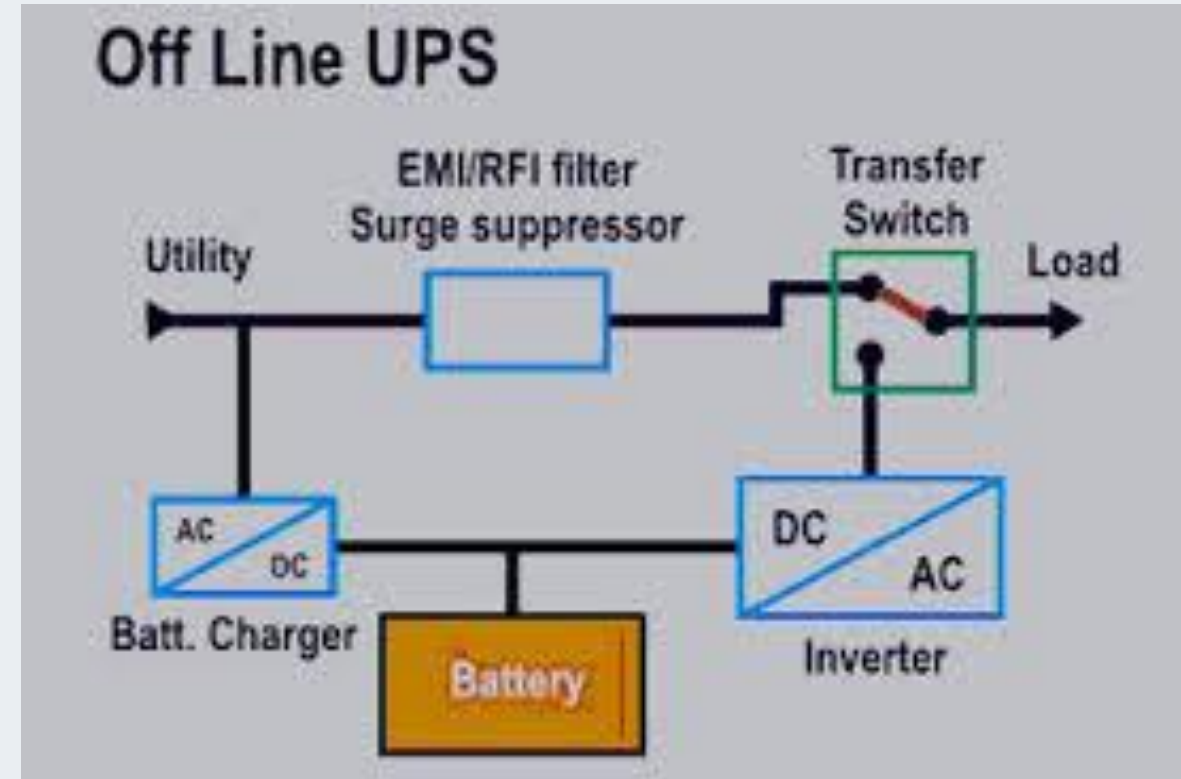

Various types of UPS

Line-Interactive UPS

A popular choice for small businesses and servers that balances cost with better protection.

- **How it works:** It uses an **Automatic Voltage Regulator (AVR)** to correct minor voltage fluctuations (brownouts or surges) without draining the battery.
- **Pros/Cons:** Offers more stability than standby models.

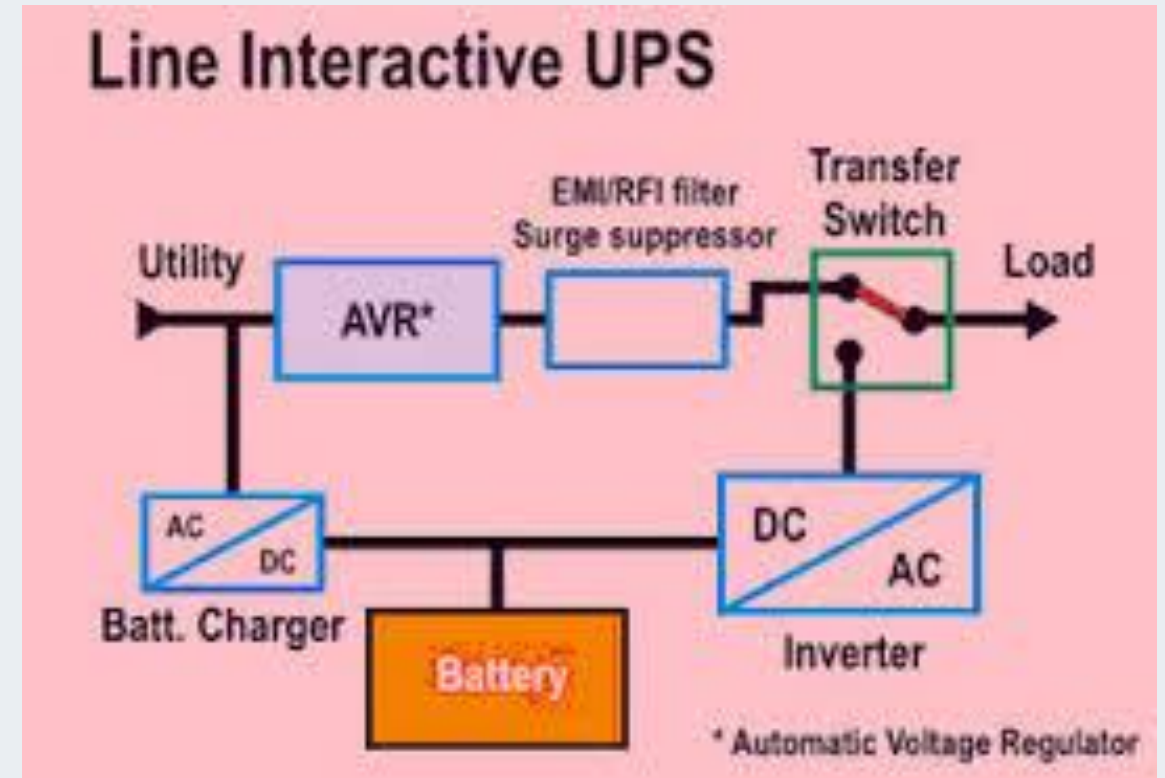

Various types of UPS

Online (Double-Conversion) UPS

The highest level of protection is required for mission-critical systems such as data centres and medical equipment.

How it works: It continuously converts incoming AC power to DC and then back to AC. This "double conversion" ensures the output is always clean and stable, regardless of input quality.

Pros/Cons: It features zero transfer time because the battery is already part of the power path. However, it is generally more expensive and less energy-efficient.

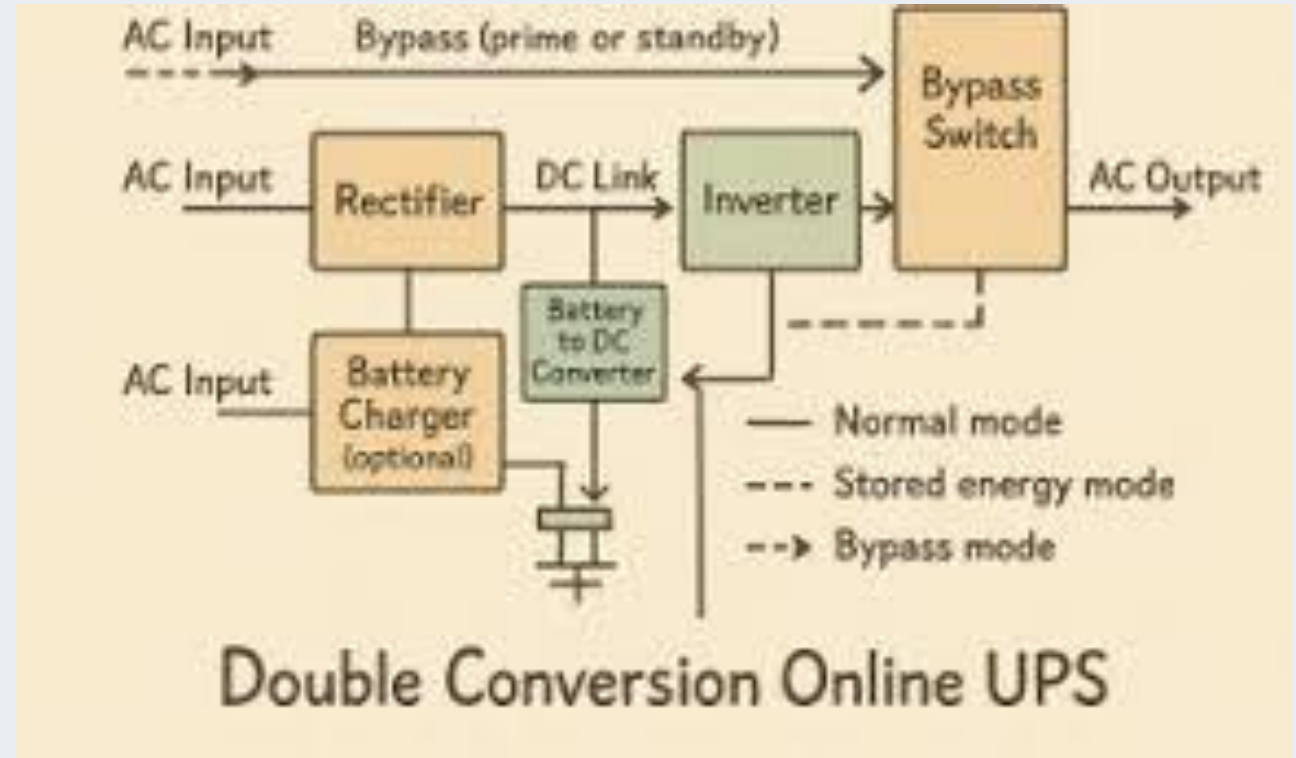

Critical Facilities Usually Use:

Online Double Conversion UPS

Comparison Summary of different UPS

Feature 	Standby (Offline)	Line-Interactive	Online (Double-Conversion)
Protection Level	Basic	Moderate	Maximum
Transfer Time	2–10 ms	4–6 ms	0 ms (Seamless)
Best Use Case	Home PC, router	Small servers, NAS	Data centres, critical IT
Voltage Regulation	No (Battery only)	Yes (AVR)	Yes (Continuous)

Online UPS Operation

Double Conversion Principle

Power Flow:

AC Input → Rectifier → DC Bus → Inverter → Load

Battery connected to:

DC Bus

During Blackout:

Battery supplies the inverter instantly

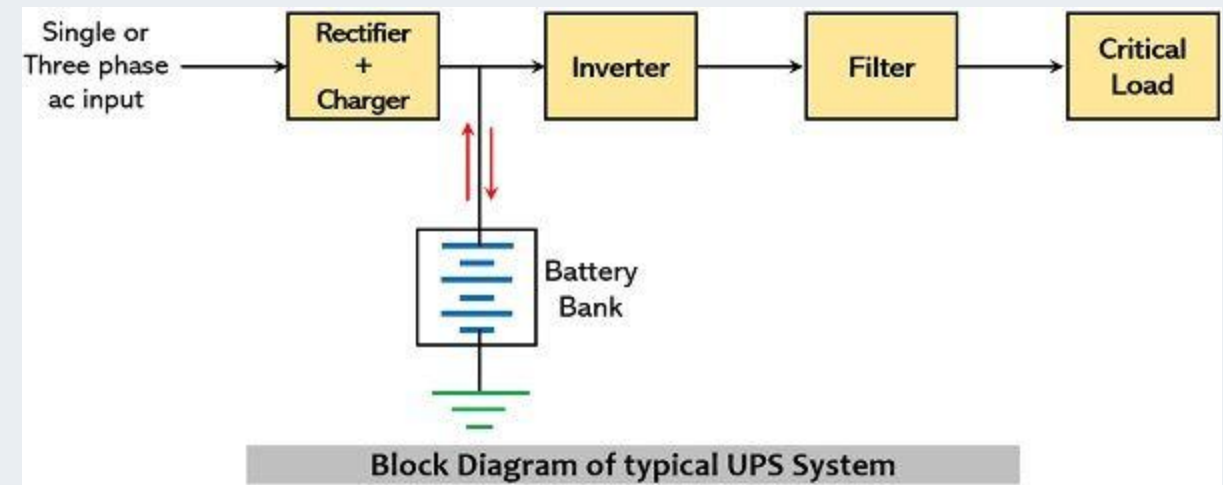

Typical Testing Methods

What Maintenance Usually Tests

Common Routine Checks

- Battery terminal voltage
- Float voltage verification
- Charger operation
- Alarm functionality
- Short discharge tests
- Bypass transfer tests
- Visual inspection
- Thermal scanning

Problem:

These may not simulate real blackout conditions.

	Year																			
	1	2	3	4	5	6	7	8	9	10	11	12	13	14	15	16	17	18	19	20
Preventive maintenance (PM)																				
UPS PM /with infrared scan	♦	♦	♦	♦	♦	♦	♦	♦	♦	♦	♦	♦	♦	♦	♦	♦	♦	♦	♦	♦
Battery PM	♦	♦	♦	♦	♦	♦	♦	♦	♦	♦	♦	♦	♦	♦	♦	♦	♦	♦	♦	♦
Thermography (infrared scan)	♦	♦	♦	♦	♦	♦	♦	♦	♦	♦	♦	♦	♦	♦	♦	♦	♦	♦	♦	♦
Replacement parts																				
Air filter	♦	♦	♦	♦	♦	♦	♦	♦	♦	♦	♦	♦	♦	♦	♦	♦	♦	♦	♦	♦
Static switch fan					♦					♦					♦					♦
Fan					♦					♦					♦					♦
ISBM interface PCB										♦										♦
UPM interface PCB										♦										♦
ISBM control board										♦										♦
UPM control board										♦										♦
Static switch board												♦								
Power module										♦										♦
ISBM power supply PCB										♦										♦
UPM power supply PCB										♦										♦
Mini CSB PCB										♦										♦
Display assembly										♦										♦
Battery (VRLA)			—	—						—	—									—
Battery (wet cell)																				♦
AC capacitor					—	—					—	—								♦
DC capacitor (9390/9395)																				♦
DC capacitor 9315					—	—					—	—								♦
Spare parts kits available																				
Additional services and upgrades																				
<ul style="list-style-type: none"> • kVA upgrade: Increase the power capacity of your UPS • Cellwatch battery monitoring: Daily battery monitoring increases overall system reliability • eNotify Remote Monitoring: 24x7 real-time monitoring of your UPS and battery systems by trained Eaton personnel • Energy Saver System (ESS): Reduce your utility bill by maximizing the efficiency of your UPS to 99% without sacrificing reliability (9390 and 9395 UPS models) • Firmware upgrade: Available as part of a UPS standard contract 																				

Hidden Failure Mode #1

Battery Capacity Collapse

Batteries Passed Voltage Tests

But:

Could Not Supply Required Current

Why?

- Sulphation
- Plate degradation
- Internal corrosion
- Electrolyte stratification
- Aged battery strings

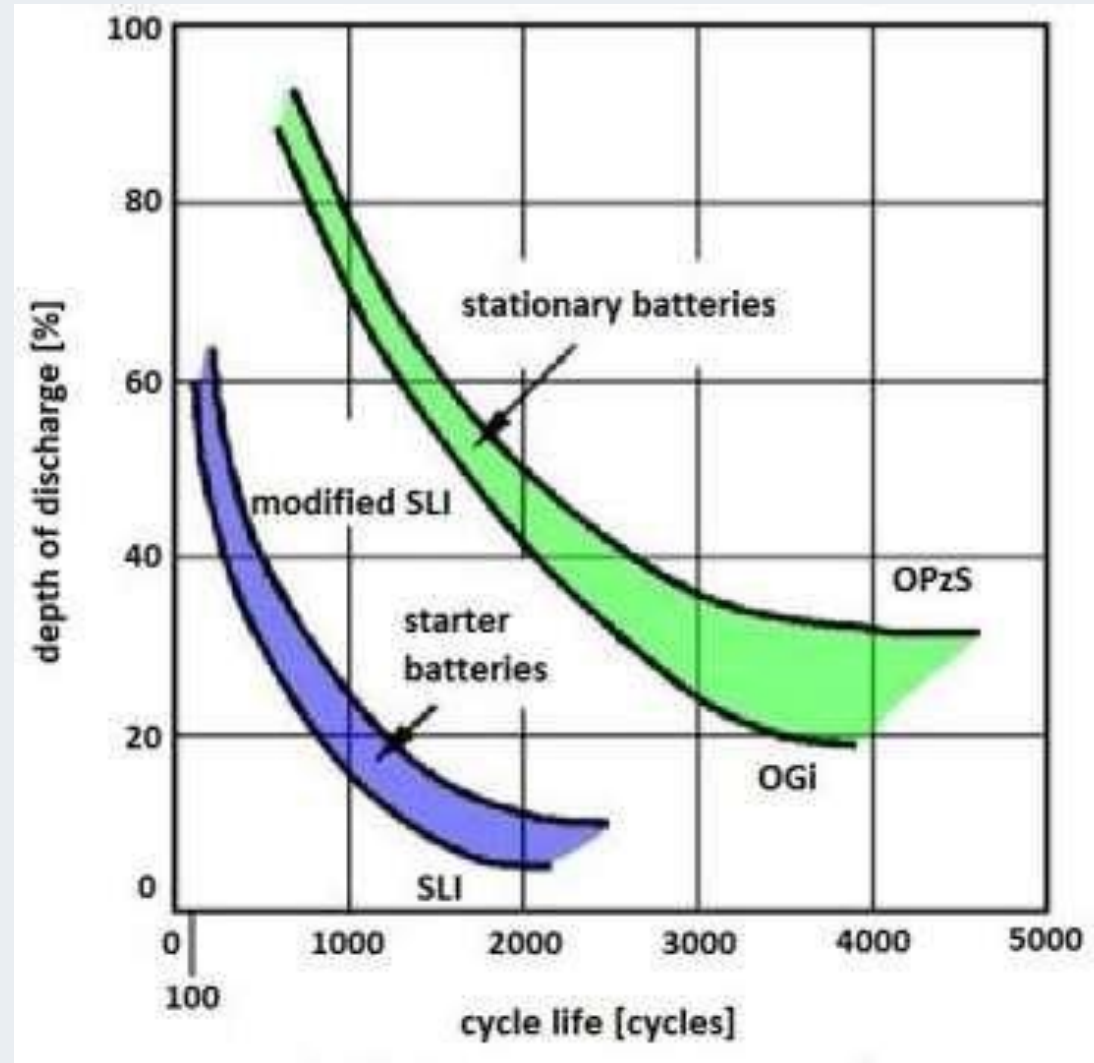

Battery Internal Resistance

The Silent Killer

Increased Internal Resistance Causes:

- Voltage collapse under load
- Rapid discharge failure
- Localized heating
- Cell imbalance

Yet:

Terminal voltage may appear normal.

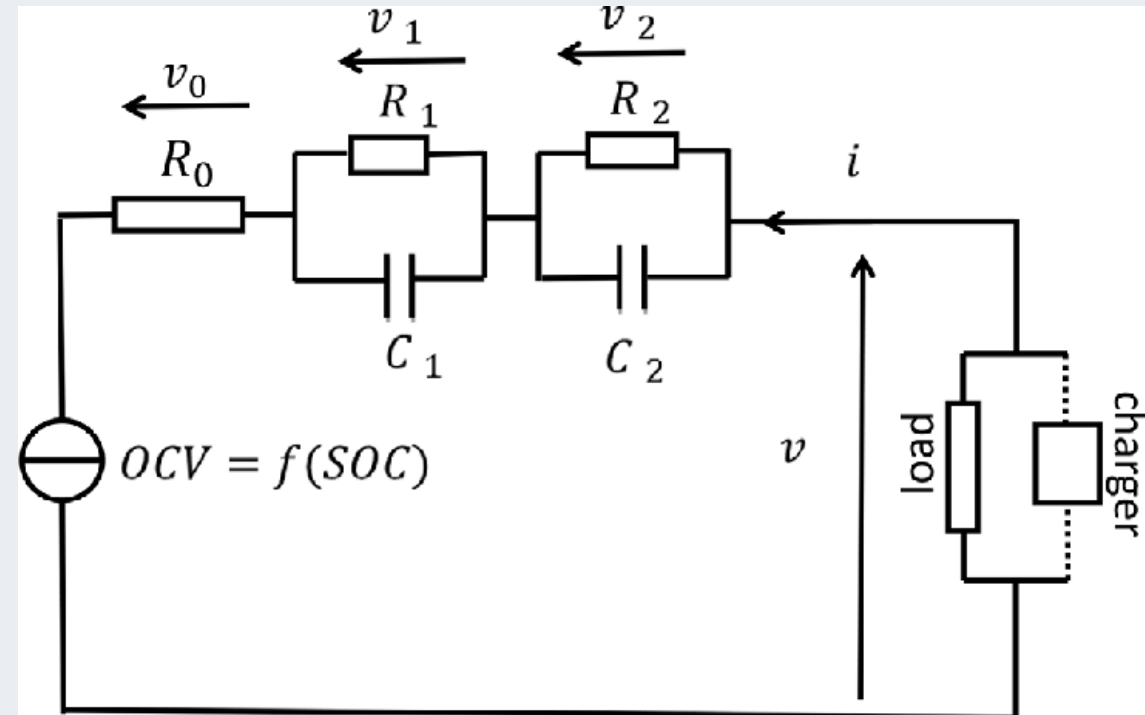

Example Failure

Real Event Example

During Test:

Load = 15%

During Blackout:

Load = 85%

Result:

Battery voltage collapsed in 12 seconds

Root Cause:

The battery bank had only 28% actual capacity.

Typical Li-ion Discharge Voltage Curve

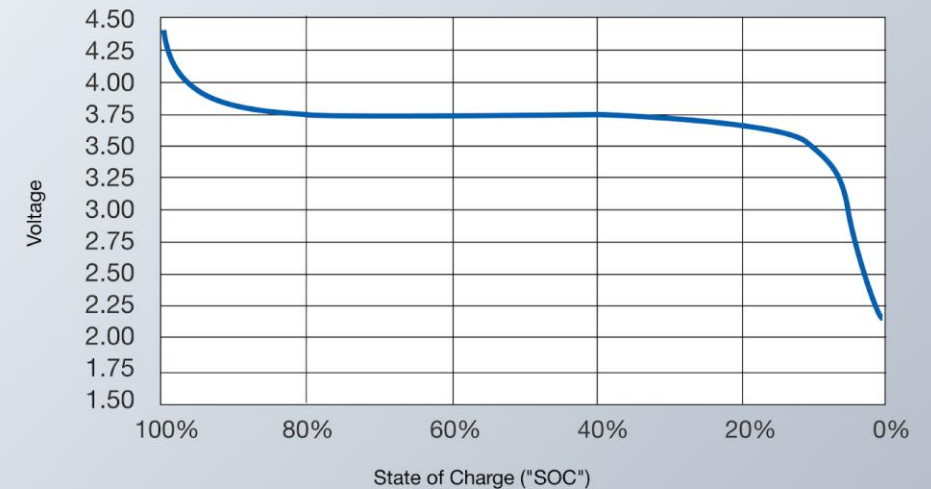

Hidden Failure Mode #2

Weak Battery Interconnections

Problems Include:

- Loose terminals
- Corroded connectors
- Poor torque settings
- Oxidised contact surfaces

Result:

High resistance → sudden failure



Hidden Failure Mode #3

Inverter Control Failure

Possible Issues:

- Firmware faults
- Gate driver failure
- Synchronization errors
- DSP malfunction
- Protection misoperation

System Status:

Looks healthy until the transition event occurs.



Hidden Failure Mode #4

Static Switch Transfer Failure

Static Switch Must:

Transfer load instantly.

Failure Causes:

- SCR malfunction
- Control logic delay
- Synchronisation failure
- Bypass path issue

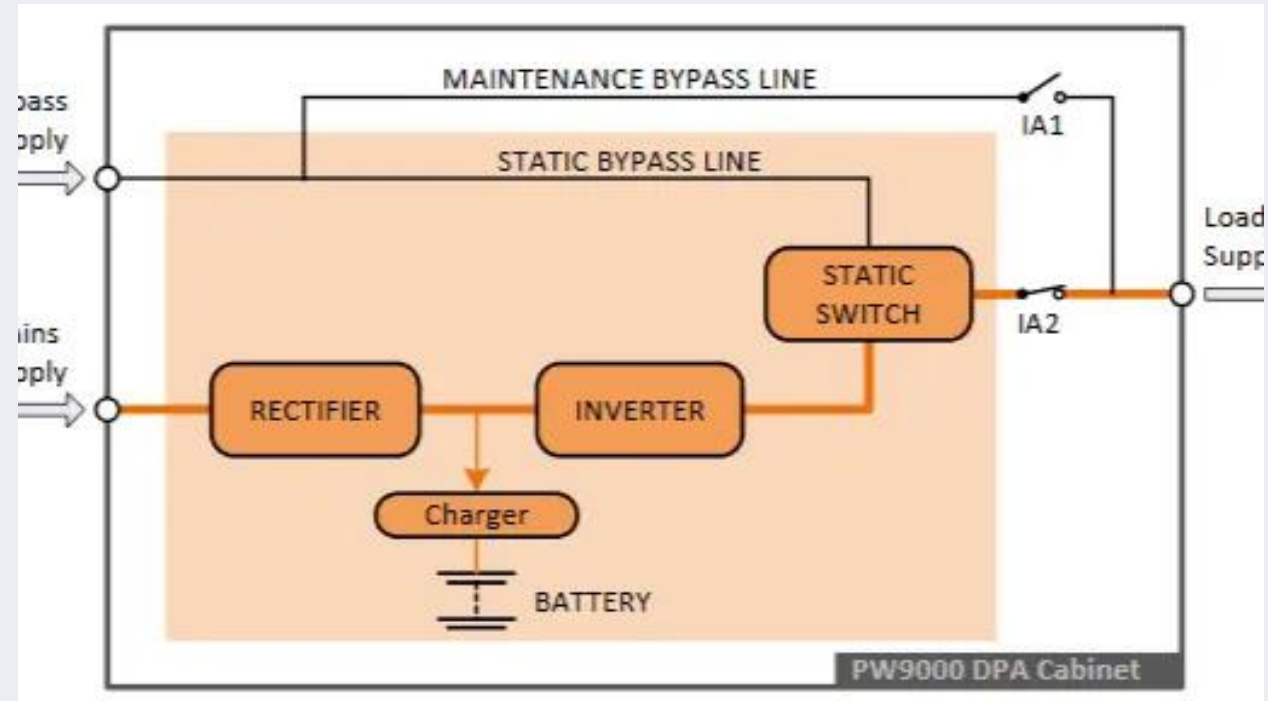

Hidden Failure Mode #5

Generator Interaction Problem

Sequence:

Blackout → UPS → Generator Starts

Problem:

Generator startup instability causes the UPS to trip.

Causes:

- Frequency drift
- Voltage overshoot
- Harmonics
- Poor synchronisation

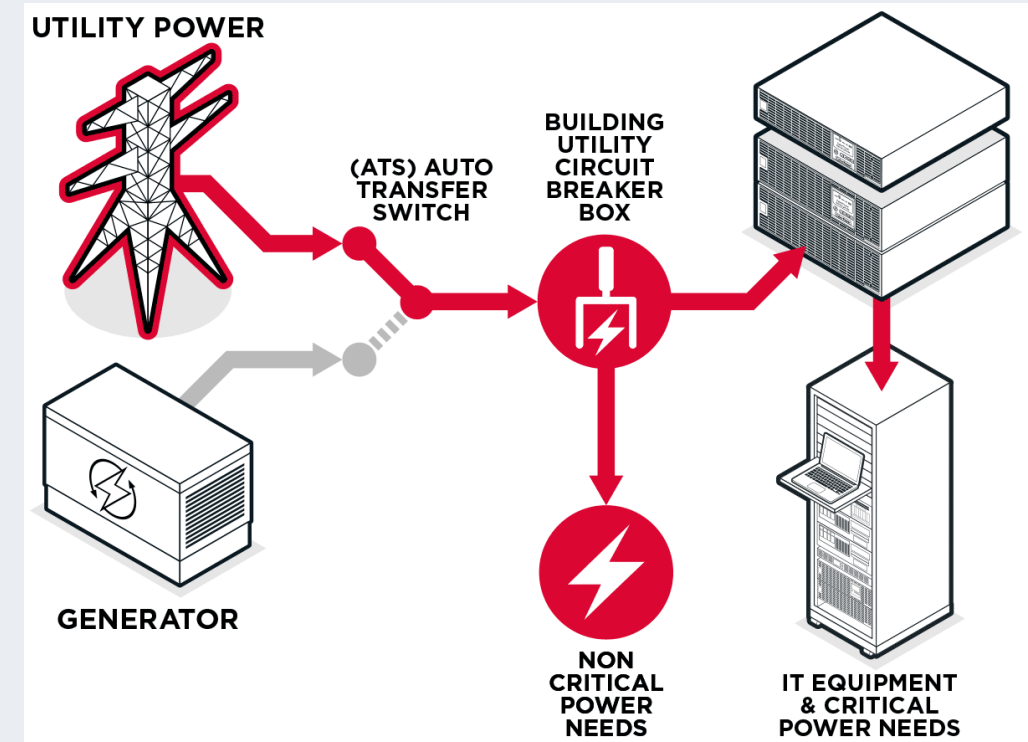

Hidden Failure Mode #6

Overloaded UPS During Real Event

Normal Condition:

Partial load

Blackout Condition:

Unexpected full load

Why?

- Emergency systems all start.
- Inrush current surge.
- HVAC restart.
- Medical equipment startup.

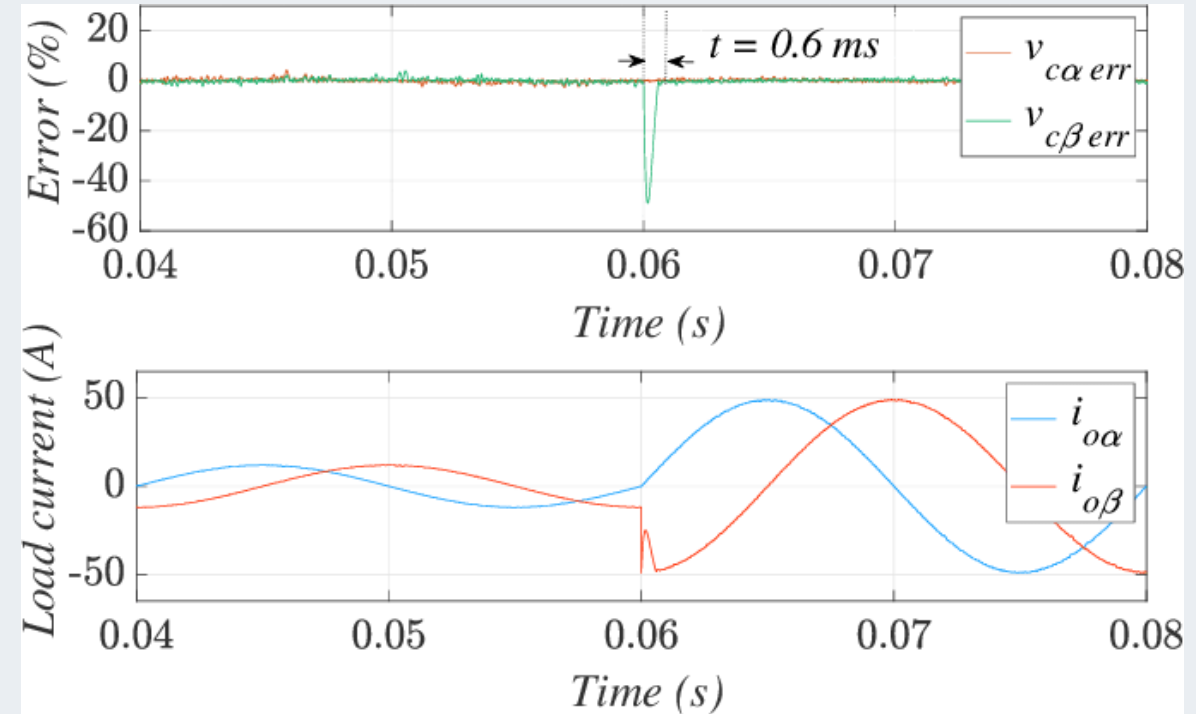

Hidden Failure Mode #7

Harmonic Distortion

Nonlinear Loads Cause:

- Excess neutral currents
- Overheating
- Inverter stress
- False protection trips

Common Sources:

- Servers
- VFDs
- LED drivers
- Medical imaging equipment

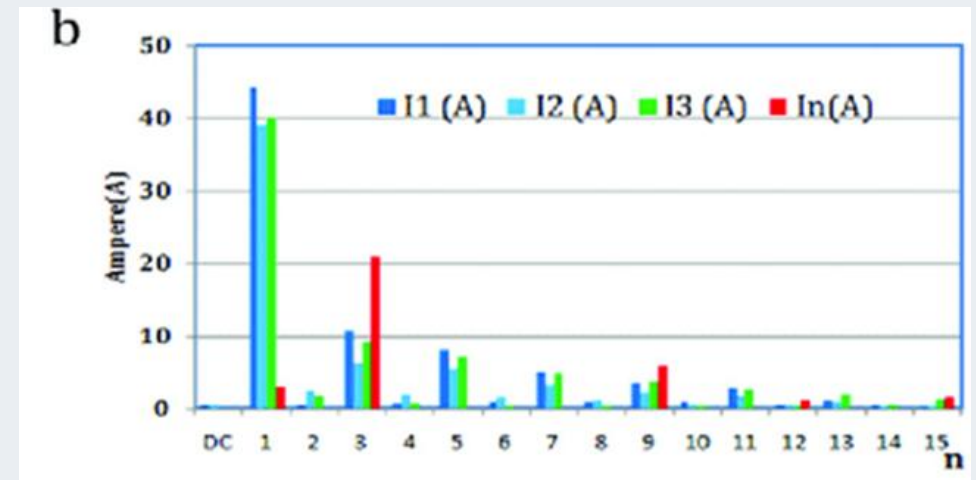
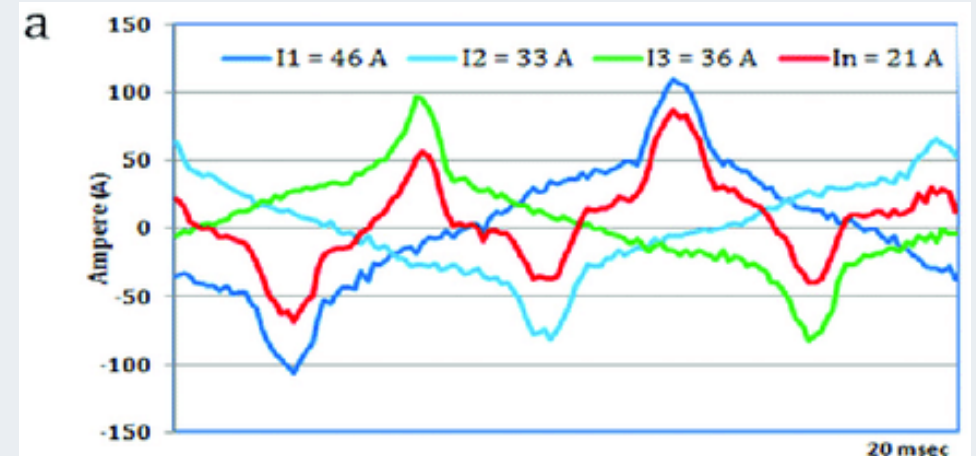

Hidden Failure Mode #8

Incorrect Maintenance Assumptions

Dangerous Beliefs:

- “Voltage is fine”
- “No alarms means healthy”
- “Passed monthly test”
- “Vendor says normal”

Reality:

Functional failure can still exist.



The Human Factor

Maintenance Culture Problem

Common Issues

- Checklist mentality
- Incomplete testing
- Lack of load testing
- Poor documentation
- No root cause analysis
- Vendor dependency



Preventive Maintenance Checklist of UPS

ForumElectrical.Com				
Cabinet	UPS Maintenance Checklist			
Description	Status	Date	Performed By	Remarks
Contact TOC Operator				
Is UPS Working Properly?				
Check Condition of the UPS				
Are proper indicator lights on				
Is the unit wired properly				
Is there evidence of pest infestation				
Computer Interface Testing				
Status				
Runtime				
Input Voltage				
Output Voltage				

The Correct Test

True Performance Testing

Better Methods

- Full load discharge testing.
- Battery impedance testing.
- Thermal imaging.
- Dynamic transfer testing.
- Generator-UPS integrated testing.
- Harmonic analysis.



Design Improvement

Better Engineering Design

Recommendations

- N+1 redundancy.
- Battery monitoring systems.
- Separate critical load segregation.
- Improved grounding.
- Generator compatibility studies.
- Predictive maintenance.

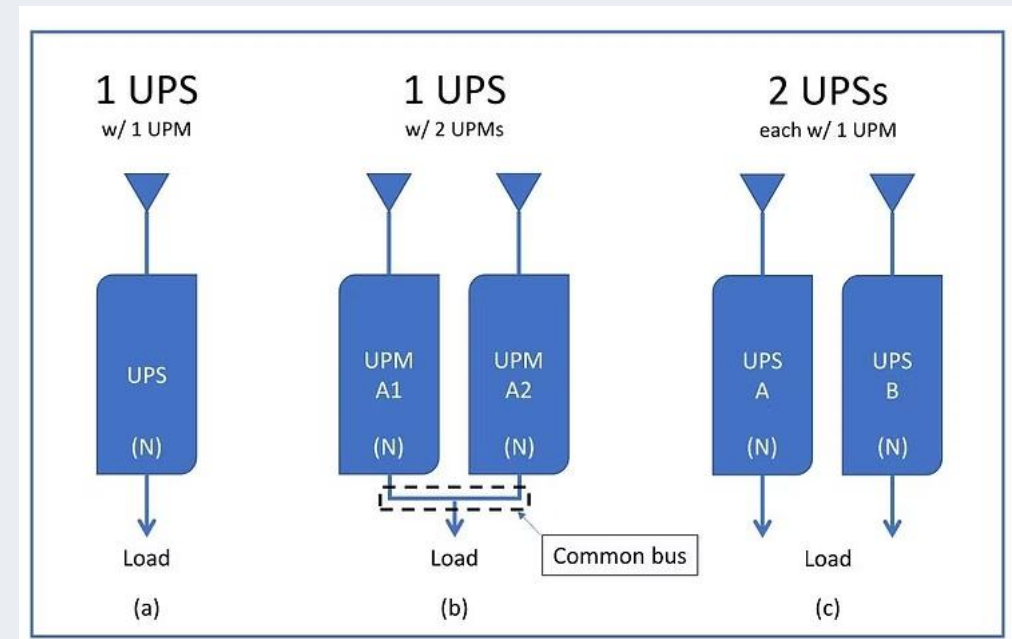

Case Study Summary

Final Investigation Revealed:

- Battery capacity degraded.
- One inter-cell connector overheated.
- Generator frequency drift caused inverter rejection.

Combined Failure

Not a single fault—but a failure chain.

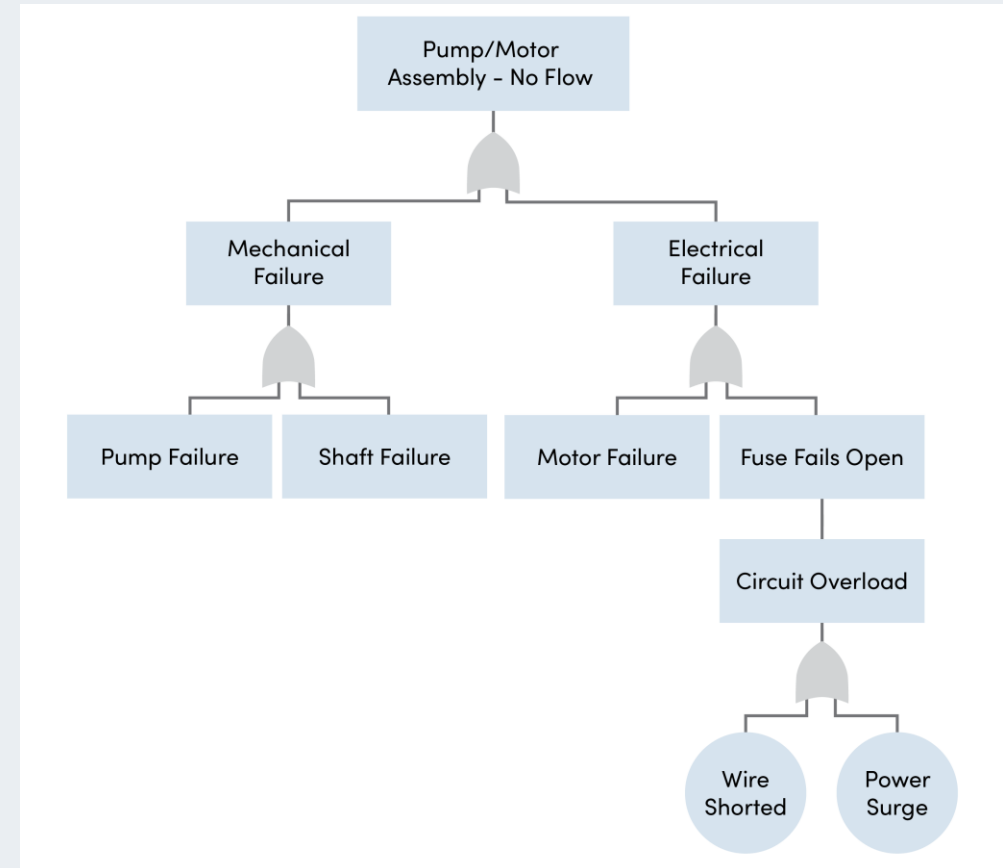

Lessons for Engineers

Key Lessons

Engineers Must Ask:

- What was tested?
- What was not tested?
- What assumptions were made?
- What happens during real stress?

Reliability Requires:

Scepticism and Verification.



Discussion Questions

Questions

1. Should battery load testing be mandatory?
2. Is monthly inspection enough?
3. Can AI improve UPS predictive maintenance?
4. How should hospitals prioritize redundancy?
5. Should generator and UPS be treated as one system?



Final Engineering Principle

The Most Dangerous Failure:

The system that appears healthy — Until the exact moment it is needed.

Engineering Principle:

“Reliability is proven under stress, not during inspection.”



Upcoming Mysteries Webinars



Register now!

11 June – Cable That Melted at 60% Load

18 June - The Phantom Neutral - Why the Feeder Voltage Floated Overnight?

9 July – The Relay That Refused to See a Short

16 July - The Capacitor Bank That Blew Itself Up Quietly

13 August – The Motor That Wouldn't Start - Unless It Was Empty

20 August - The Neon Sign That Pulsed with Passing Trucks

10 September – The Battery Bank That Lost Capacity Overnight

17 September - The Streetlight That Kept Turning on at Noon

12 November – The Transformer That Changed Tap Position by Itself

19 November – The Circuit That Lost Half Its Phase Over the Years

10 December – The PLC That Spoke Back - A Control Loop with a Mind of Its Own

17 December - The Resonant Substation - Lights Flicker Without Load Change

27 January - The Induced Voltage That Woke the Cattle



Thank You!

Upcoming Courses



Please note: courses listed below are subject to their own regulatory requirements—refer to the relevant website for further information.

Engineering Institute of Technology (EIT) <i>Australian Accredited Qualifications & Short Courses</i>	Start Date
Graduate Diploma of Engineering (Electrical Systems)	29 June 2026
Master of Engineering – Applied Research (Electrical Systems)	29 June 2026
Online - Master of Engineering (Electrical Systems)	29 June 2026
Graduate Certificate in Power System Analysis and Design	29 June 2026
Bachelor of Science (Electrical Engineering)	20 July 2026
Associate Degree in Electrical Engineering	20 July 2026
Doctor of Engineering	20 July 2026
Professional Certificate of Competency in Fundamentals of Electric Vehicles	11 August 2026
Professional Certificate of Competency in Battery Energy Storage and Applications	8 September 2026
Professional Certificate of Competency in Onshore and Offshore Pipeline Systems	8 September 2026
Professional Certificate of Competency in Circuit Breakers, Switchgear and Power Transformers	13 October 2026

Upcoming Courses



Please note: courses listed below are offered by separate institutions in the UK and South Africa, each subject to their own regulatory requirements - refer to the relevant website for location-specific details.

Engineering College of Technology (ECT) <i>UK qualifications</i>	Start Date
Master of Science (Power System Analysis and Renewable Integration)	1 June 2026
Master of Science (Industrial Automation and Instrumentation Control)	1 June 2026
Bachelor of Engineering (Honours) in Electrical Engineering	21 September 2026
Bachelor of Engineering (Honours) in Industrial Automation	21 September 2026

Engineering College of Science and Technology (ECST) <i>South African accredited qualification & ECSA-endorsed</i>	Start Date
Bachelor of Engineering Technology in Electrical Engineering	3 August 2026

Q&A



Contact Us:



Website

www.eit.edu.au



Head Office

6 & 8 Thelma Street, West Perth,
Perth, WA 6005



Phone

Inside Australia: 1300 138 522
Outside Australia: +61 8 9321 1702



Email

webinars@eit.edu.au



Courses

<https://www.eit.edu.au/schedule/>



Website

www.ect.ac.uk



Head Office

Whittle Way, Stevenage SG1 2FS,
United Kingdom



Phone

Inside UK: 0208 335 4014
Outside UK: +44 208 335 4014



Programmes

<https://www.ect.ac.uk/programmes/>



Website

www.ecst.ac.za



Head Office

Unit 3, Elevation Gardens,
Elevation Close, Waterfall
Office Park, Midrand, 1686



Phone

Within South Africa: 010 823 4497
Outside South Africa: +27 11 823 4497



Programmes

[www.ecst.ac.za/course-
types/bachelor-of-engineering/](http://www.ecst.ac.za/course-types/bachelor-of-engineering/)